



July 08, 2009

 All Articles Products Courses Papers News Webinars Web
Site Search:

[LOGIN](#) [REGISTER](#) [Welcome, Guest](#) [Home](#) [RSS](#) [Design Center](#) [Learning Center](#) [Product Center](#) [News](#) [Blogs](#) [Forums](#) [Careers](#) [Site Features](#)

Selection and integration of MEMS-based motion processing in consumer apps

By Steve Nasiri, David Sachs and Michael Maia, [InvenSense, Inc.](#)

Motion processing, which measures and intelligently processes the movements of devices in three dimensional spaces, is the next major disruptive technology that will drive innovation in handheld consumer electronic (CE) product design, human interface design, and application navigation and control.

Driving this revolution is the availability of consumer-grade inertial measurement units (IMUs) based on micro-electromechanical systems, or MEMS. These devices, when combined for six axes of motion processing, provide a simpler user interface for intuitive navigation and control of handheld CE products by resolving the operating complexities that have confused many owners of sophisticated devices.

Enabling this six axes of control using MEMS motion processing is the recent availability of smaller, lower cost, and high performance three-axis MEMS gyroscopes that can be used in combination with existing three-axis MEMS accelerometers.

This paper will define a six-axis motion processing solution and examine critical factors involved in the selection and integration of this technology into everyday consumer electronic systems. Assuring compliance of the four critical factors outlined in this article will lead to higher integration efficiency when implementing new designs with six-axis motion processing, resulting in excellent performance in the end user device.

Motion-processing applications

At the Electronic Entertainment Exposition (E3) all three major game console brands demonstrated some form of motion-actuated human interface for their current or next-generation systems, with Nintendo being the first to announce the commercial availability of a six-axis motion processing solution in the [Wii MotionPlus](#) accessory. Console game software developers quickly introduced new game titles to take advantage of six-axis motion processing functionality: Nintendo is set to release the sequel to the popular Wii Sports title in July 2009 with [Wii Sports Resort](#). Early product reviews acknowledge the higher precision and 1:1 tracking of controller movements with on-screen game play enabled by motion-processing.

Mobile handsets are the next frontier for motion processing as consumers have already embraced the novel features provided by three-axis accelerometers. The Apple iPhone is a case in point and Apple continues to develop unique motion-sensing applications, including the addition of a shake-to-undo motion gesture for its iPhone 3.0 during copy and paste functions, as well as App Store applications which turns the iPhone into a light saber. The addition of six-axis motion processing to future mobile handsets, and other handheld CE systems, delivers console gaming performance to these products, while giving software developers measurements of the handset's absolute position in 3D space with higher precision, accuracy and responsiveness.

Where once being first to market with traditional buttons and wheels might have been key to a design's success, in this fast-changing environment, that success will depend on who can create the most compelling

user experience where complex control and navigation commands may now be executed with common hand motions enabled by this six-axis motion processing.

Motion processing solution

The key enabling technology for delivering motion processing capability is the gyroscope, which is traditionally used for measuring absolute rate of rotation. Vibratory mass gyros use energy transfer between the two resonating modes of a structure due to Coriolis acceleration, which arises in a rotating reference frame and is proportional to the rate of rotation as shown below in **Figure 1**. Gyroscopes measure angular velocity (Ω) by sensing Coriolis acceleration.

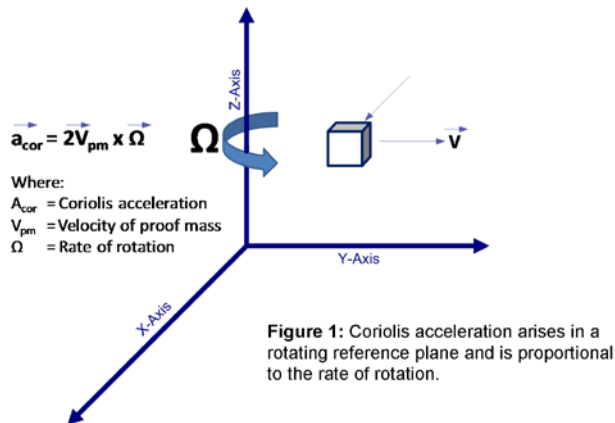

Vibratory tuning fork mass gyroscope implementations typically contain a pair of vibrating masses that are driven to oscillation with equal magnitude and in opposite directions. When the gyro device is rotated, the Coriolis force creates an orthogonal vibration force proportional to the rate of rotation, which is typically measured using capacitive sensing techniques between comb "fingers" along the perimeter of the oscillating proof mass structure and the comb of the stationary frame surrounding the proof mass. Good gyroscope designs have high Coriolis acceleration and low mechanical noise. Achieving high Coriolis acceleration requires a higher proof mass velocity, which is actuated by electrostatic forces, and achieving high sensitivity requires less integrated circuit (IC) amplification, which leads to lower noise.

While accelerometers provide basic motion sensing for simple orientation and tilt applications, there are limitations that affect accelerometer operation and performance in more complex applications, such as optical image stabilization (OIS). Accelerometers can only deliver the sum of linear and centripetal acceleration, gravity and vibration. Extracting a single element of the accelerometer's linear motion information is not feasible without the addition of a gyroscope. A gyroscope is required to accurately measure angular rate of rotational movement within the motion processing solution.

To provide corrections for rotation error in the accelerometers, some vendors use magnetometer sensors as a solution to fill the sensing need traditionally met by gyroscopes. These devices determine the rotational movement of a handheld device relative to magnetic north and are typically used to reorient a displayed map to correspond to the general direction a user is facing. Magnetometers are inadequate for fast rotational measurements (greater than 5 Hz) and are prone to data corruption in the presence of external magnetic fields, such as in the presence of a speaker or audio headset, or simply in the presence of ferrous materials within the device or its surroundings. Gyroscopes are the only inertial sensors that provide accurate, latency-free measurement of rotations without being affected by any external forces, including magnetic, gravitational or other environmental factors.

The introduction of silicon MEMS-based technology has enabled new MEMS gyroscopes that are no longer cost-prohibitive for consumer electronics and are suitable for achieving a challenging industry cost target of

less than \$1.00 USD per axis, while meeting the package size and the appropriate level of rotational sensing accuracy to become suitable for mobile phones, game controllers, remote controls and portable navigation devices. Motion processing solutions have been enabled by smaller, high performance, low cost MEMS gyroscopes and their companion MEMS accelerometers, as shown in **Figure 2**.

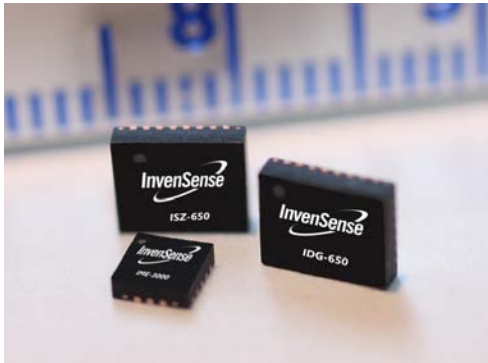

Figure 2: InvenSense™ integrated 6-axis motion processing solution with 7x7mm total area

Both gyro and accelerometer are needed

To meet the end-user's functional expectations, three axes of rotation and three axes of linear motion are required. There is a common misperception that engineers must select either a gyroscope or an accelerometer to add motion-processing functionality within their handheld systems. Indeed, industry analysts have posed the question, "which motion sensor will win the race?"

The reality is that accurately interpreting both linear and rotational motion requires designers to include both the gyroscope and the accelerometer. Pure gyroscopic solutions can be used for rotation detection with high resolution and quick response. Pure accelerometer-based solutions can be used for applications with fixed reference from gravity as well as linear or tilt movement, constrained to limited rotation. But simultaneous processing by the motion processing solution of linear movement and rotation requires both gyroscopes and accelerometers. When tracking pitch and roll, accelerometers provide a better measurement when the device is not moving, yet MEMS gyros provide a higher accuracy when the device is in motion. Sensor fusion algorithms are typically used to combine accelerometer and gyroscope data as described in **Figure 3**. This allows accurate rotational measurements with a wide bandwidth.

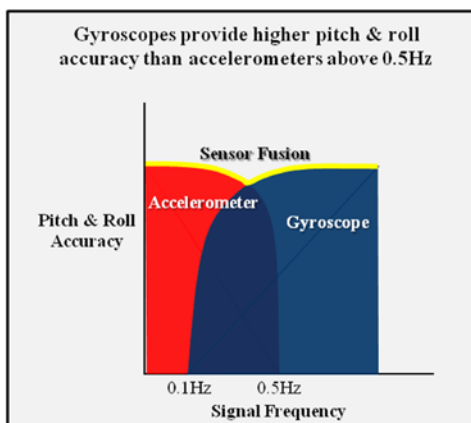

Figure 3: Sensor Fusion algorithms combine accelerometer and gyroscope data to cover a wider signal frequency range of motions.

The selection of the proper motion processing solution involves careful analysis of many factors, including the device's full scale range, sensitivity, offset performance, noise, cross-axis sensitivity and the effects of temperature, humidity and mechanical g-shock on the product. The next section of this paper focuses on four key factors to consider when making these sensors work together within a CE application.

Motion processing design considerations

Engineers adopting six-axis motion-processing functionality within their CE applications are faced with the choice of either assembling gyroscopes and accelerometers from multiple sources, or selecting a fully integrated solution from a vertically integrated motion-processing supplier. While there are merits and challenges to each approach, the motion processing product selection should consider the following interoperability points:

1. To maximize the value of motion processing functionality, the design may include multiple applications, such as GPS navigation heading assist, mobile gaming and a motion-based user interface. Each of these applications requires different gyroscope data sampling rates and anti-aliasing measures must be employed to ensure motion data accuracy through the use of low pass filtering (LPF) that is specific to the particular application.
2. Accurate timing data is essential to determine the gyroscope's angular data calculations through mathematical integration.
3. Synchronous sampling of the accelerometer and gyroscope data will ensure high quality position coordinate information.
4. The drive, sense and harmonic frequencies of gyroscopes should be designed not to interfere with each other or any other frequencies within the system.

Gyroscopes and accelerometers are typically shown in product selector guides based on their core specifications, yet it is useful to associate sensor specifications with their typical applications. The **Table** shown below describes applications for analog gyroscopes with their full scale range expressed in degrees-per-second (dps) and the corresponding sensitivity shown in millivolt-per-dps. Digital accelerometers are commonly used in motion processing solutions, describing their full scale range in a g-rating and sensitivity ratings in least-significant-bit (LSB) per *g*.

Typical Application	Gyro Sensitivity	Gyro Full Scale Range (FSR)
Image Stabilization	20 to 50 mV/dps	20 to 43 dps
Navigation	4 to 15 mV/dps	50 to 67 dps
3-D Remote Control	2.0 mV/dps	500 dps
Game Controller	0.5 mV/dps	2,000 dps

Table: Typical gyroscope sensitivity and full-scale range by application.

1: Filtering considerations

Flexible filtering is generally required in motion applications since noise and signal bandwidth requirements typically vary with the action being performed. There are two primary filtering techniques: 1) in the analog domain, typically performed with the analog-to-digital converter (ADC) anti-aliasing filter or an RC (resistor, capacitor) circuit, and 2) in the digital domain, performed with a digital processor after the system ADC. The analog filter is always required to prevent aliasing.

For motion processing applications with variable bandwidths, the optimal choice is to include a programmable digital filter after the analog filtering. As an example of variable bandwidth requirements, consider a gaming application. Certain sports games frequently contain fast movements which demand wider bandwidths. In other games which require drawing or selecting on-screen menu options, higher precision is necessary where a narrower bandwidth and lower noise are preferred.

Motion processing equipped mobile devices will enable multiple applications such as gaming, camera image

stabilization, user interface and automotive navigation, each requiring different signal bandwidths. For example, to capture a user's gaming motions up to 10-Hz signal frequencies, a sampling rate of 200 Hz may be required which results in the need for a low-pass filter (LPF) below 100 Hz based on the Nyquist rule (which calls for removal of any signal that is greater than or equal to half the desired sampling frequency). Similarly, to gather automotive navigation heading signals up to 1 Hz, a sampling frequency of 10 Hz with an LPF cutoff frequency of less than 5 Hz is required.

The challenge for anti-aliasing of multiple motion processing functions is that the 100-Hz LPF suitable for gaming applications may result in undesirable noise for the navigation application, while a 5-Hz LPF is too low for gaming and introduces latency. The solution for those applications requiring variable filter bandwidths is to use an anti-aliasing filter that meets the widest bandwidth requirement (gaming in this case), while using a programmable digital filter to meet those applications with more stringent noise requirements.

When selecting a non-integrated motion processing solution (**Figure 4**), a dedicated microcontroller may be required that would continuously sample at 100 Hz using a 5-Hz digital LPF within the device and output at 10 Hz. The drawback is the additional cost of a microcontroller which precludes their use in cost-sensitive CE applications.

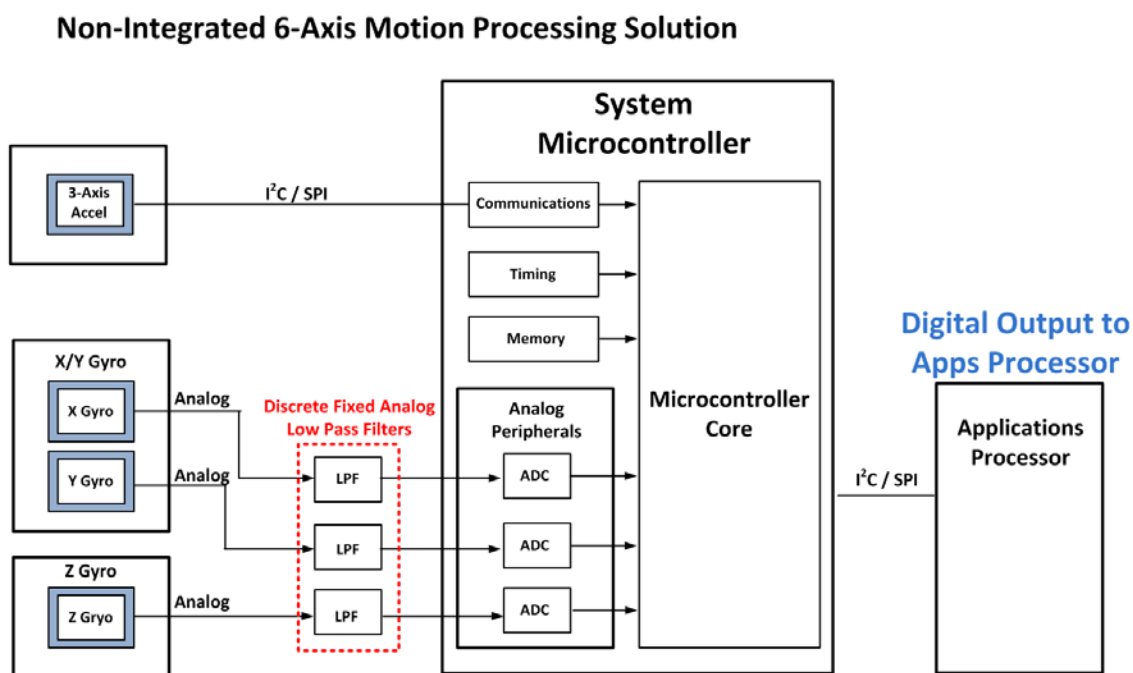

Figure 4: Non-integrated solutions using disparate motion sensors requires signal conditioning with discrete fixed functionality.

As part of its signal processing, the fully integrated six-axis motion processing solution (**Figure 5**) has fixed-frequency anti-aliasing filters as part of its ADC block, followed by programmable digital LPFs which negate the need for external signal conditioning and microcontrollers.

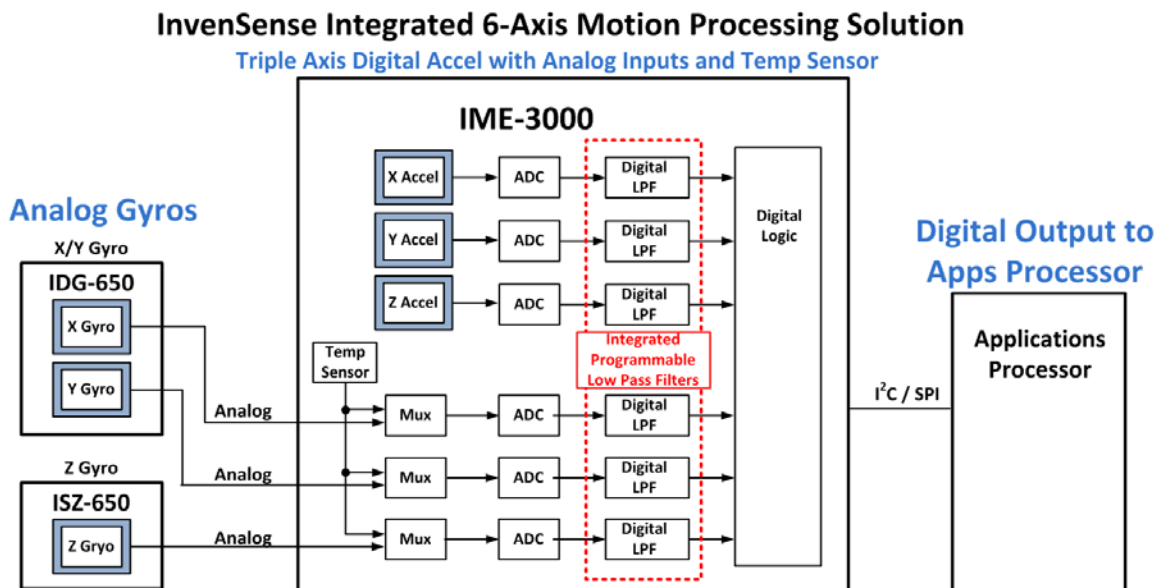

Figure 5: An integrated motion processing solution with programmable signal conditioning eliminates the need for fixed frequency external low pass filters.

2: Timing accuracy

Timing accuracy is important when determining the angular data of the gyro, which is the product of the angular velocity measurements at the sampling frequency. The following equation describes the angular measurements determined over the sampling rate:

$$\alpha = \omega \times \Delta T$$

Where:

- α = Gyroscope angular data
- ω = Gyroscope angular velocity
- ΔT = Time increment

Angular measurements determined over the sampling rate.

The equation shows that timing accuracy of the gyro is equally as important as the angular velocity data; inaccurate timing data results in poor angular data estimates. Today's microcontrollers are tasked with multiple timing functions, for example, to update the display, report a touch screen event, or answer an incoming phone call. With all of these disparate timing demands, it is likely that precise gyro timing data updates will not consistently occur at the desired rate, which adversely impacts the angular data calculations.

The current generation of mobile handsets does not perform sensor data integration over time and are not concerned with timing inaccuracies as an accelerometer combined with a compass sensor only provides rudimentary motion sensing features such as tilt sensing and absolute location. Yet as more handsets deploy multiple sensors, including gyroscopes, as part of a multi-axes motion processing system, an integrated solution designed to eliminate the need for a microcontroller by providing pre-calibrated synchronous timing

between the accelerometer and gyroscopes is required. By way of example, the [InvenSense six-axis motion processing solution](#) integrates three high resolution auxiliary ADCs which interface directly to the dual-axis and single-axis gyro analog outputs, along with internal programmable low pass filters for anti-aliasing functionality of multiple motion-based applications.

3: Synchronizing motion-processing data

As multiple motion sensors are deployed within handheld CE applications, it is important to properly synchronize the sensor data collection, which is challenging for non-integrated motion-processing solutions. Higher accuracy may be achieved when gathering both accelerometer and gyro data simultaneously, however, if each sensor has its own timing requirements, interpolation may be required which complicates the motion algorithm.

There may be different methods for retrieving data from multiple motion sensors, such as gathering data from a digital accelerometer available through the I²C interface with a particular sampling frequency, that may not be compatible with the analog gyro data that must be digitally converted by the internal lower-resolution ADCs from the system microcontroller. The advantage of a tightly integrated six-axis motion processing solution is that it ensures that all accelerometer and gyro data is properly synchronized for higher precision with lower design complexity.

4: Frequency compliance

As the final consideration, the engineer must ensure that the gyroscope's drive, sense and harmonic frequencies do not interfere with each other or any other component operating frequencies to minimize distortion of the sensor fusion output. Gyros with acoustic sensitivity operating in the sub-5-kHz range cannot be used near audio sources, such as TVs, video games, radios, human speech, sirens, automobiles or audible alarms. Speakers used in CE applications typically operate in the 20-Hz to 20-kHz range, while OIS actuators operate in the 500-Hz to 4-kHz range, which by example, would not interfere with the InvenSense integrated MEMS motion processing drive frequencies of X-axis 24 kHz, Y-axis 27 kHz and Z-axis 30 kHz. These drive and sensing frequencies were specifically selected to not interfere with each other while avoiding the audio frequency range and camera OIS actuation systems.

It is imperative that motion processing solutions achieve higher levels of integration going forward and the design considerations reviewed here will assist engineers in selecting a solution for a fully integrated motion processing system and remove barriers to adoption into consumer electronics designs.

About the authors

Steve Nasiri, CEO and founder, David Sachs, Sr. application engineer and Michael Maia, vice president of marketing, [InvenSense, Inc.](#)