



InvenSense Inc.

1197 Borregas Ave., Sunnyvale, CA 94089 U.S.A.
Tel: +1 (408) 988-7339 Fax: +1 (408) 988-8104
Website: www.invensense.com

AN-MPU-6000A-08
Revision: 1.0
Release Date: 09/20/11

MPU-6050™
Sensor Board for Atmel AVR UC3
Microcontroller



Table of Contents

1. REVISION HISTORY	3
1. PURPOSE.....	4
2. DESCRIPTION.....	4
3. HARDWARE LAYOUT	5
4. SCHEMATIC.....	6



**MPU-6050™ Sensor board for Atmel AVR UC3
Microcontroller**

AN-MPU-6000A-08
Revision: 1.0
Release Date: 9/20/11

1. Revision History

Revision Date	Revision	Description
9/20/11	1.0	Initial Release



1. Purpose

The MPU-6050 sensor board is designed to be plug compatible with Atmel Xplain MCU boards. The MPU-6050 sensor board delivers a sensor platform with full nine-degrees-of-freedom — combining accelerometer, compass, gyroscope, and temperature sensor—that is ideal for developing motion sensing or user interface applications.

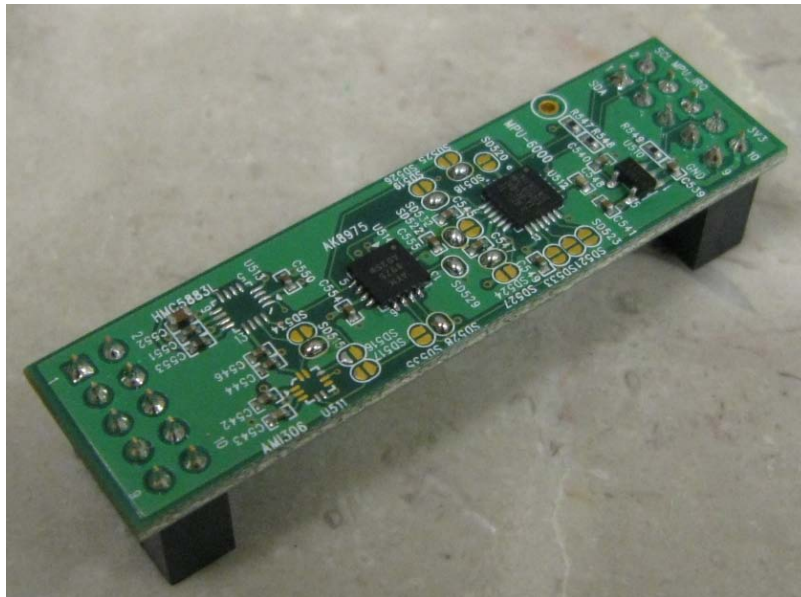

2. Description

The MPU-6050 sensor board provides sensing capability with full nine-degrees-of freedom from a set of inertial sensors. The sensors are interfaced via the I²C serial digital interface connected through a common header that is compatible with Xplain MCU boards. This sensor cluster is well suited for cell phones, handheld devices, computer peripherals, man-machine interfaces, virtual reality features, and game controllers. The following sensors are incorporated into this development board, and detailed explanations of their operation can be obtained from the relevant partner's component data sheets.

2.1. InvenSense Six-Axis Motion Processor (MPU-6050)

The MPU-6050 is a single-chip, digital-output, six-axis MEMS gyroscope and accelerometer IC optimized for gaming, 3D mice, and 3D remote control applications. The MPU-6050 features 16-bit analog-to-digital converters (ADCs) for digitizing the gyroscope and accelerometer outputs, a user-selectable internal low-pass filter, and a fast-mode I²C (400kHz) interface. Additional features include an embedded motion processor and a temperature sensor.

2.2. AKM Three-Axis Electronic Compass (AK8975)

The AK8975 contains highly sensitive Hall sensor technology that incorporates magnetic sensors for detecting terrestrial magnetism in the X-axis, Y-axis, and Z-axis; a sensor driving circuit; a signal

amplifier chain; and an arithmetic circuit for processing the signal from each sensor. It is suitable for map heading purposes in GPS-equipped products to realize pedestrian navigation functionality.

3. Hardware Layout

Figure 3-1 shows the physical arrangement of the sensors on the MPU-6050 sensor board. All three sensors have their X, Y, and Z axes aligned, and a symbol is provided to indicate their directional alignment.

Figure 3-1. Sensor arrangement

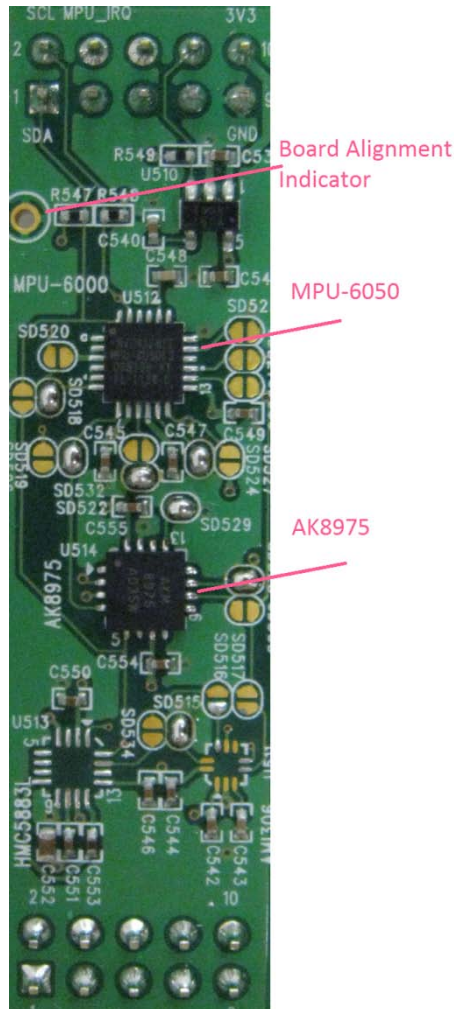

The MPU-6050 sensor board must be attached to the correct headers on the Xplain MCU board to ensure proper operation. All the sensor development boards attach to headers J1 and J2 on the MCU board, and a board alignment indicator is printed on the board to aid correct alignment. As an example, Figure 3-2 shows the orientation of the MPU-6050 sensor board when attached to the UC3-A3 Xplained MCU board.



Figure 3-2. Correct board attachment orientation.

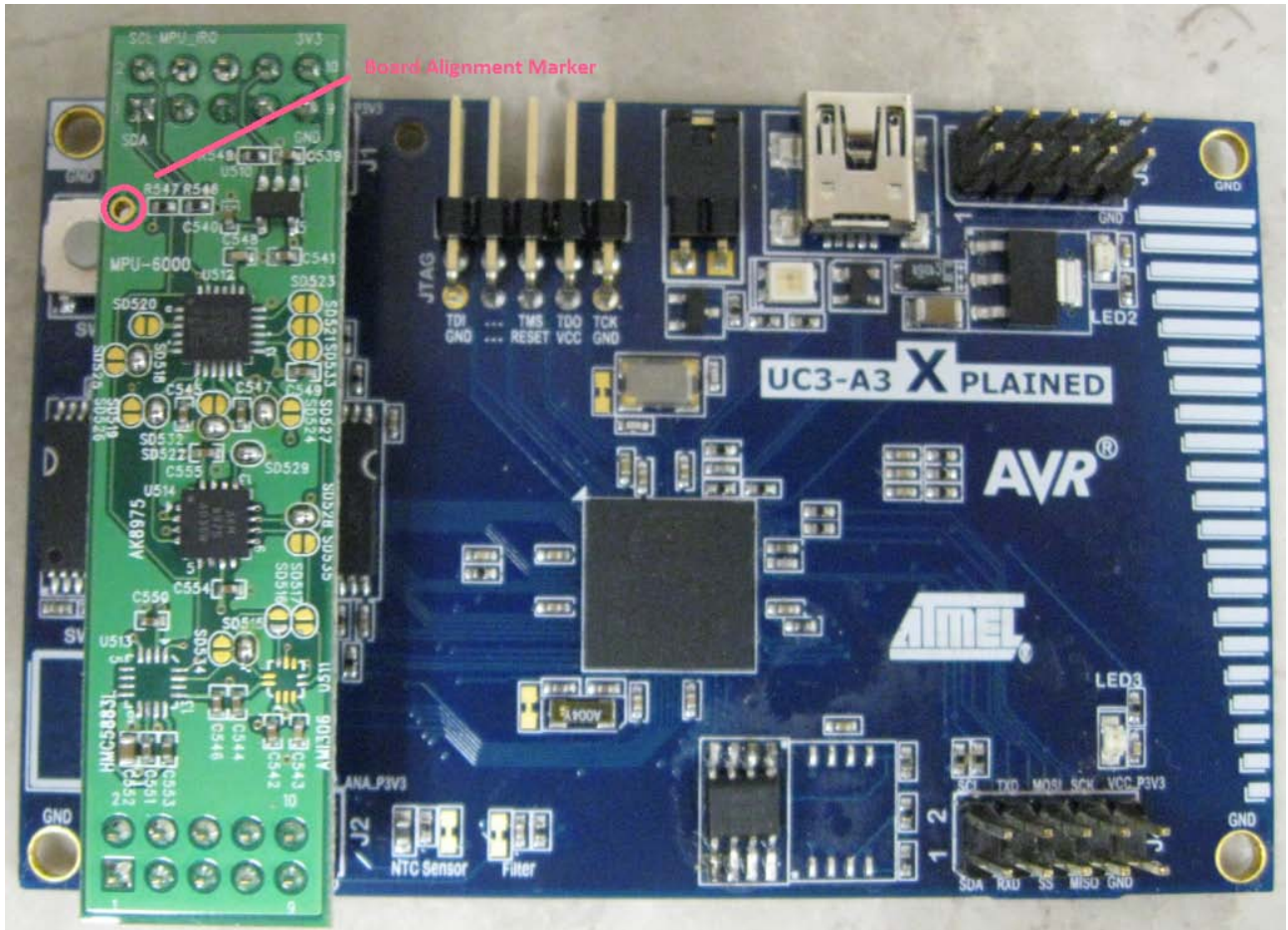

4. Schematic

Figure 4-1 shows the schematic for the MPU-6050 sensor board, and Table 4-1 gives the I2C addresses for the three sensors.

NOTE, The I2C pull-up resistors are included on the sensor board.

Figure 4-1. MPU-6050 sensor board schematic.

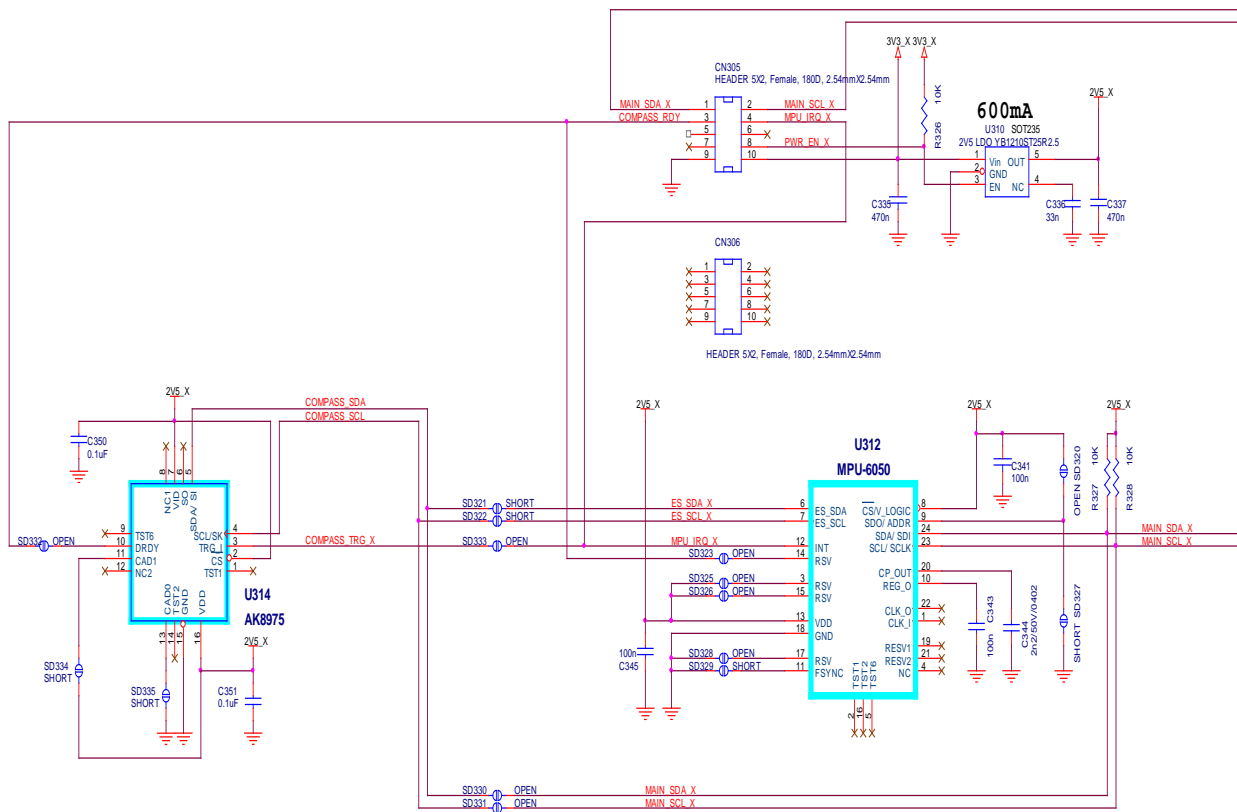

Sensor	7 bit I2C address
MPU-6050	0x68
AK8975	0x0E

Table 4-1. Sensor I2C addresses.

The power supplied to the digital header on the Xplained series of sensor boards is nominally set to 3.3V. The MPU-6050 Sensor board has an on-board 2.5V regulator to supply power to all three sensors.



**MPU-6050™ Sensor board for Atmel AVR UC3
Microcontroller**

AN-MPU-6000A-08
Revision: 1.0
Release Date: 9/20/11

This information furnished by InvenSense is believed to be accurate and reliable. However, no responsibility is assumed by InvenSense for its use, or for any infringements of patents or other rights of third parties that may result from its use. Specifications are subject to change without notice. InvenSense reserves the right to make changes to this product, including its circuits and software, in order to improve its design and/or performance, without prior notice. InvenSense makes no warranties, neither expressed nor implied, regarding the information and specifications contained in this document. InvenSense assumes no responsibility for any claims or damages arising from information contained in this document, or from the use of products and services detailed therein. This includes, but is not limited to, claims or damages based on the infringement of patents, copyrights, mask work and/or other intellectual property rights.

Certain intellectual property owned by InvenSense and described in this document is patent protected. No license is granted by implication or otherwise under any patent or patent rights of InvenSense. This publication supersedes and replaces all information previously supplied. Trademarks that are registered trademarks are the property of their respective companies. InvenSense sensors should not be used or sold in the development, storage, production or utilization of any conventional or mass-destructive weapons or for any other weapons or life threatening applications, as well as in any other life critical applications such as medical equipment, transportation, aerospace and nuclear instruments, undersea equipment, power plant equipment, disaster prevention and crime prevention equipment.

InvenSense™ is a registered trademark of InvenSense, Inc., MPU-6050™ is a trademark of InvenSense, Inc. Other trademarks are property of their respective owners.

©2011 InvenSense, Inc. All rights reserved.

