



IMU-3000
Motion Processing Unit
Product Specification
Rev 1.3

Preliminary

CONTENTS

1	DOCUMENT INFORMATION	4
1.1	REVISION HISTORY	4
1.2	PURPOSE AND SCOPE.....	6
1.3	PRODUCT OVERVIEW.....	6
1.4	SOFTWARE SOLUTIONS.....	7
1.5	APPLICATIONS.....	8
2	FEATURES	9
2.1	SENSORS.....	9
2.2	DIGITAL OUTPUT	9
2.3	MOTIONPROCESSING.....	9
2.4	CLOCKING.....	9
2.5	POWER.....	9
2.6	PACKAGE.....	9
3	ELECTRICAL CHARACTERISTICS	10
3.1	SENSOR SPECIFICATIONS	10
	GYRO MECHANICAL FREQUENCIES.....	10
3.2	ELECTRICAL SPECIFICATIONS.....	11
3.3	ELECTRICAL SPECIFICATIONS, CONTINUED.....	12
3.4	ELECTRICAL SPECIFICATIONS, CONTINUED.....	13
3.5	13
3.6	I ² C TIMING CHARACTERIZATION	14
3.7	ABSOLUTE MAXIMUM RATINGS.....	15
4	APPLICATIONS INFORMATION	16
4.1	PIN OUT AND SIGNAL DESCRIPTION.....	16
4.2	TYPICAL OPERATING CIRCUIT.....	17
4.3	BILL OF MATERIALS FOR EXTERNAL COMPONENTS.....	17
4.4	RECOMMENDED POWER-ON PROCEDURE	18
5	FUNCTIONAL OVERVIEW.....	19
5.1	BLOCK DIAGRAM	19
5.2	OVERVIEW	19
5.3	THREE-AXIS MEMS GYROSCOPE WITH 16-BIT ADCs AND SIGNAL CONDITIONING.....	19
5.4	DIGITAL MOTION PROCESSOR.....	20
5.5	PRIMARY I ² C SERIAL COMMUNICATIONS INTERFACE.....	20
5.6	SECONDARY I ² C SERIAL INTERFACE FOR THIRD-PARTY ACCELEROMETER	20
5.7	INTERNAL CLOCK GENERATION	22
5.8	CLOCK OUTPUT.....	23
5.9	SENSOR DATA REGISTERS.....	23
5.10	FIFO.....	23
5.11	INTERRUPTS	23
5.12	DIGITAL-OUTPUT TEMPERATURE SENSOR.....	23
5.13	BIAS AND LDO.....	23
5.14	CHARGE PUMP	23
6	DIGITAL INTERFACE.....	24
6.1	I ² C SERIAL INTERFACE.....	24
7	SERIAL INTERFACE CONSIDERATIONS.....	27



7.1 SUPPORTED INTERFACES.....27

7.2 LOGIC LEVELS.....27

8 ASSEMBLY.....30

8.1 ORIENTATION OF AXES30

8.2 PACKAGE DIMENSIONS31

8.3 PCB DESIGN GUIDELINES.....32

8.4 ASSEMBLY PRECAUTIONS33

8.5 REFLOW SPECIFICATION35

8.6 STORAGE SPECIFICATIONS36

8.7 PACKAGE MARKING SPECIFICATION.....36

8.8 TAPE & REEL SPECIFICATION.....37

8.9 LABEL38

8.10 PACKAGING39

9 RELIABILITY40

9.1 QUALIFICATION TEST POLICY40

9.2 QUALIFICATION TEST PLAN40

10 ENVIRONMENTAL COMPLIANCE41

Preliminary



1 Document Information

1.1 Revision History

Revision Date	Revision	Description
05/26/2010	1.0	Initial Release
08/19/2010	1.1	<ul style="list-style-type: none">• Changes for readability (multiple sections)• Modified following specifications (Section 3.1)<ul style="list-style-type: none">○ ZRO Tolerance○ ZRO Variation over Temperature○ Total RMS Noise○ Noise spectral density○ Temperature Sensor Operating Range• Modified following specifications (Section 3.2)<ul style="list-style-type: none">○ Operating Current○ Digital Input: Input Capacitance• Modified Capacitance for each IO Pin for Secondary I²C (Section 3.3)• Modified Clock Frequency Initial Tolerance for CLKSEL=0, 25°C (Section 3.4).• Modified I²C Timing: Capacitive Load for Each Bus Line (Section 3.5)• Added Latch-up specification (Section 3.6).• Modified 3rd party accel /CS connection in diagram. (Section 7.3.1)• Added AUX register listing (Section 9).• Added AUX register description (Section 10.12).• Modified PCB Design Guidelines (Section 11.2.2).• Modified Reflow Specification (Section 11.9)• Added Environmental Compliance information (Section 13).
05/19/2011	1.2	<ul style="list-style-type: none">• Removed MPL Section• Created separate document for Register Information• Added section describing software solutions (Section 1.4)• Added SDA and SCL to Digital Output specification (Section 3.2)• Added CLKOUT Digital Output specification (Section 3.2)• Updated Latch up Absolute Maximum rating (Section 3.7)• Fixed C1 and C2 Specifications (Section 4.3)• Clarified T_{VLG-VDD} value (Section 4.4)• Documented inoperable primary bus when VDD is low and interface pins are low impedance (Section 5.5)• Documented gyro access capability in Pass-Through Mode (Section 5.6)• Documented the Secondary I²C bus Internal Pull Up configuration (Section 5.6)• Modified diagrams to clarify usage of 3rd party accelerometers (Section 7.2)• Modified Package Marking diagram for clarify (Section 8.13)• Modified Assembly rules and Moisture Sensitivity Level (MSL) Label• Updated Reliability Section (Section 9)



IMU-3000 Product Specification

Document Number: PS-IMU-3000A-00
Revision: 1.3
Release Date: 05/25/2011

05/25/2011

1.3

- Fixed Digital Input Spec. from VDD to VLOGIC (Section 3.2)
- Specified CLKIN to be connected to GND if unused (Section 4.1)
- Sec. 4.4 Modified T_{VDDR} value for consistency with Electrical Characteristics

Preliminary

1.2 Purpose and Scope

This document is a preliminary product specification, providing a description, specifications, and design related information for the IMU-3000™ Inertial Measurement Unit (IMU™).

Electrical characteristics are based upon simulation results and limited characterization data of advanced samples only. Specifications are subject to change without notice. Final specifications will be updated based upon characterization of final silicon.

1.3 Product Overview

The IMU-3000 is the world's first IMU solution with 6-axis sensor fusion using its field-proven and proprietary MotionFusion™ engine for consumer applications. The IMU-3000 has an embedded 3-axis gyroscope and Digital Motion Processor™ (DMP™) hardware accelerator engine with a secondary I²C port that interfaces to third party digital accelerometers to deliver a complete 6-axis MotionFusion output to its primary I²C port. This combines both linear and rotational motion into a single data stream for the application. The device is ideally suited for a wide variety of consumer products requiring a rugged, low-cost MotionProcessing™ solution for applications in game controllers, remote controls for broadband connected TVs and set top boxes, sports, fitness, medical and other applications. By providing an integrated MotionFusion output, the IMU-3000 offloads the intensive MotionProcessing computation requirements from the host processor, reducing the need for frequent polling of the motion sensor output and enabling use of low cost, low power microcontrollers.

The IMU-3000 features a 3-axis digital gyro with programmable full-scale ranges of ±250, ±500, ±1000, and ±2000 degrees/sec (dps), which is useful for precision tracking of both fast and slow motions. Rate noise performance sets the industry standard at 0.01 dps/√Hz, providing the highest-quality user experience in pointing and gaming applications. Factory-calibrated initial sensitivity reduces production-line calibration requirements. The part's on-chip FIFO and dedicated I²C-master accelerometer sensor bus simplify system timing and lower system power consumption; the sensor bus allows the IMU-3000 to directly acquire data from the off-chip accelerometer without intervention from an external processor, while the FIFO allows a system microcontrollers to burst read the sensor data and then go to sleep while the IMU collects more data. Other industry-leading features include on-chip 16-bit ADCs, programmable digital filters, a precision clock with 1% variation from -40°C to 85°C, an embedded temperature sensor, programmable interrupts, and a low 13mW power consumption. Parts are available with an I²C serial interface, a VDD operating range of 2.1 to 3.6V, and a VLOGIC interface voltage from 1.71V to 3.6V.

By leveraging its patented and volume-proven Nasiri-Fabrication platform, which integrates MEMS wafers with companion CMOS electronics through wafer-level bonding, InvenSense has driven the IMU-3000 package size down to a revolutionary footprint of 4x4x0.9mm (QFN), while providing the highest performance, lowest noise, and the lowest cost semiconductor packaging to address a wide range of handheld consumer electronic devices. The device provides the highest robustness by supporting 10,000g shock in operation. The highest cross-axis isolation is achieved by design from its single silicon integration.

The IMU-3000 was designed to connect directly with a third-party 3-axis digital accelerometer, which slaves directly to the IMU-3000 master and can be clocked from the internal phase locked loop of the IMU-3000 device, providing highly accurate timing for a true 6-axis MotionProcessing solution previously only available in costly and bulky inertial measurement units.



1.4 Software Solutions

This section describes the MotionApps™ software solutions included with the InvenSense MPU (Motion Processing Unit) and IMU (Inertial Measurement Unit) product families. Please note that the products within the IDG, IXZ, and ITG families do not include these software solutions.

The MotionApps Platform is a complete software solution that in combination with the InvenSense IMU and MPU MotionProcessor families delivers robust, well-calibrated 6-axis and/or 9-axis sensor fusion data using its field proven and proprietary MotionFusion™ engine. Solution packages are available for smartphones and tablets as well as for embedded microcontroller-based devices.

The MotionApps Platform provides a turn-key solution for developers and accelerates time-to-market. It consists of complex 6/9-axis sensor fusion algorithms, robust multi-sensor calibration, a proven software architecture for Android and other leading operating systems, and a flexible power management scheme.

The MotionApps Platform is integrated within the middleware of the target OS (the sensor framework), and also provides a kernel device driver to interface with the physical device. This directly benefits application developers by providing a cohesive set of APIs and a well-defined sensor data path in the user-space.

The table below describes the MotionApps software solutions included with the InvenSense MPU and IMU product families.

InvenSense MotionProcessor Devices and Included MotionApps Software

Feature	Included Software				Notes
	MotionApps	Embedded MotionApps	MotionApps Lite	Embedded MotionApps Lite	
Part Number	MPU-3050 MPU-6050		IMU-3000		
Processor Type	Mobile Application Processor	8/16/32-bit Microcontroller	Mobile Application Processor	8/16/32-bit Microcontroller	
Applications	Smartphones, tablets	TV remotes, health/fitness, toys, other embedded	Smartphones, tablets	TV remotes, health/fitness, toys, other embedded	
6-Axis MotionFusion	Yes		Yes		< 2% Application Processor load using on-chip Digital Motion Processor (DMP). Reduces processing requirements for embedded applications
9-Axis MotionFusion	Yes		No		
Gyro Bias Calibration	Yes		Yes		No-Motion calibration and temperature calibration
3 rd Party Compass Cal API	Yes		No		Integrates 3 rd party compass libraries
Gyro-Assisted Compass Calibration (Fast Heading)	Yes		No		Quick compass calibration using gyroscope
Magnetic Anomaly Rejection (Improved Heading)	Yes		No		Uses gyro heading data when magnetic anomaly is detected



The table below lists recommended documentation for the MotionApps software solutions.

Software Documentation

Platform	MotionApps and MotionApps Lite	Embedded MotionApps and Embedded MotionApps Lite
Software Documentation	<ul style="list-style-type: none">• Installation Guide for Linux and Android MotionApps Platform, v1.9 or later• MPL Functional Specifications	<ul style="list-style-type: none">• Embedded MotionApps Platform User Guide, v3.0 or later• Embedded MPL Functional Specifications

For more information about the InvenSense MotionApps Platform, please visit the Developer's Corner or consult your local InvenSense Sales Representative.

1.5 Applications

- Game controllers
- 3D Remote controls for Internet connected TVs and Set Top Boxes
- Health and sports monitoring
- Motion tracking
- Gesture recognition and advanced user interfaces

Preliminary

2 Features

The IMU-3000 Motion Processing Unit includes a wide range of features:

2.1 Sensors

- X-, Y-, Z-Axis angular rate sensors (gyros) on one integrated circuit
- Digital-output temperature sensor
- 6-axis MotionProcessing capability using secondary I²C interface to directly connect to a digital 3-axis third-party accelerometer
- Factory-calibrated scale factor
- High cross-axis isolation via proprietary MEMS design
- 10,000g shock tolerant

2.2 Digital Output

- Fast Mode (400kHz) I²C serial interface
- 16-bit ADCs for digitizing sensor outputs
- Angular rate sensors (gyros) with applications-programmable full-scale-range of $\pm 250^\circ/\text{sec}$, $\pm 500^\circ/\text{sec}$, $\pm 1000^\circ/\text{sec}$, or $\pm 2000^\circ/\text{sec}$.

2.3 MotionProcessing

- Embedded Digital Motion Processing™ (DMP™) engine supports 3D MotionProcessing. When used together with a digital 3-axis third party accelerometer, the IMU-3000 collects the accelerometer data via a dedicated interface, while synchronizing data sampling at a user defined rate. The total data set obtained by the IMU-3000 includes 3-axis gyroscope data, 3-axis accelerometer data, and temperature data.
- FIFO buffers complete data set, reducing timing requirements on the system processor and saving power by letting the processor burst read the FIFO data, and then go into a low-power sleep mode while the IMU collects more data.
- Data collection polled or interrupt driven with on-chip programmable interrupt functionality
- Programmable low-pass filters

2.4 Clocking

- On-chip timing generator clock frequency $\pm 2\%$ variation over full temperature range
- Optional external clock inputs of 32.768kHz or 19.2MHz
- 1MHz clock output to synchronize with digital 3-axis accelerometer

2.5 Power

- VDD analog supply voltage range of 2.1V to 3.6V
- Flexible VLOGIC reference voltage allows for I²C interface voltages from 1.71V to VDD
- Power consumption with all three axis active: 6.1mA
- Sleep mode: 5 μ A
- Each axis can be individually powered down

2.6 Package

- 4x4x0.9mm QFN plastic package
- MEMS structure hermetically sealed and bonded at wafer level
- RoHS and Green compliant



3 Electrical Characteristics

3.1 Sensor Specifications

Typical Operating Circuit of Section 4.2, VDD = 2.5V, VLOGIC = 2.5V, T_A=25°C.

Parameter	Conditions	Min	Typical	Max	Unit	Notes
GYRO SENSITIVITY						
Full-Scale Range	FS_SEL=0		±250		°/s	4
	FS_SEL=1		±500			4
	FS_SEL=2		±1000			4
	FS_SEL=3		±2000			4
Gyro ADC Word Length			16		Bits	3
Sensitivity Scale Factor	FS_SEL=0		131		LSB/(°/s)	1
	FS_SEL=1		65.5			3
	FS_SEL=2		32.8			3
	FS_SEL=3		16.4			3
Sensitivity Scale Factor Tolerance	25°C	-3		+3	%	1
Sensitivity Scale Factor Variation Over Temperature			±2		%	7
Nonlinearity	Best fit straight line; 25°C		0.2		%	6
Cross-Axis Sensitivity			2		%	6
GYRO ZERO-RATE OUTPUT (ZRO)						
Initial ZRO Tolerance	25°C		±20		°/s	1
ZRO Variation Over Temperature	-40°C to +85°C		±0.1		°/s/°C	7
Power-Supply Sensitivity (1-10Hz)	Sine wave, 100mVpp; VDD=2.2V		0.2		°/s	5
Power-Supply Sensitivity (10 - 250Hz)	Sine wave, 100mVpp; VDD=2.2V		0.2		°/s	5
Power-Supply Sensitivity (250Hz - 100kHz)	Sine wave, 100mVpp; VDD=2.2V		4		°/s	5
Linear Acceleration Sensitivity	Static		0.1		°/s/g	6
GYRO NOISE PERFORMANCE						
Total RMS Noise	FS_SEL=0 DLPFCFG=2 (100Hz)		0.1		°/s-rms	1
Rate Noise Spectral Density	At 10Hz		0.01		°/s/√Hz	3
GYRO MECHANICAL FREQUENCIES						
X-Axis		30	33	36	kHz	1
Y-Axis		27	30	33	kHz	1
Z-Axis		24	27	30	kHz	1
GYRO START-UP TIME						
ZRO Settling	DLPFCFG=0 to ±1°/s of Final		50		ms	5
TEMPERATURE SENSOR						
Range			-30 to 85		°C	2
Sensitivity	Untrimmed		280		LSB/°C	2
Room-Temperature Offset	35°C		-13200		LSB	1
Linearity	Best fit straight line (-30°C to +85°C)		±1		°C	2
TEMPERATURE RANGE						
Specified Temperature Range		-40		85	°C	2

Notes:

1. Tested in production
2. Based on characterization of 30 parts over temperature on evaluation board or in socket
3. Based on design, through modeling and simulation across PVT
4. Typical. Randomly selected part measured at room temperature on evaluation board or in socket
5. Based on characterization of 5 parts over temperature
6. Tested on 5 parts at room temperature
7. Based on characterization of 48 parts on evaluation board or in socket



3.2 Electrical Specifications

Typical Operating Circuit of Section 4.2, VDD = 2.5V, T_A = 25°C.

Parameters	Conditions	Min	Typical	Max	Units	Notes
VDD POWER SUPPLY						
Operating Voltage Range	Monotonic ramp. Ramp rate is 10% to 90% of the final value (see Figure in Section 4.4)	2.1		3.6	V	2
Ramp Rate		0		5	ms	2
Normal Operating Current	DMP disabled		6.1		mA	1
Sleep Mode Current			5.9		mA	1
			5		µA	4
VLOGIC REFERENCE VOLTAGE						
(Must be regulated)	VLOGIC must be ≤VDD at all times Monotonic ramp. Ramp rate is 10% to 90% of the final value (see Figure in Section 4.4)	1.71		VDD	V	3, 5
Voltage Range						
Ramp Rate						
Normal Operating Current						
START-UP TIME FOR REGISTER READ/WRITE						
			20	100	ms	4
I²C ADDRESS						
	AD0 = 0		1101000			1
	AD0 = 1		1101001			1
DIGITAL INPUTS (SDA, AD0, SCL, CLKIN)						
V _{IH} , High Level Input Voltage		0.7*VLOGIC			V	5
V _{IL} , Low Level Input Voltage				0.3*VLOGIC	V	5
C _i , Input Capacitance			< 5		pF	
DIGITAL OUTPUT (INT)						
V _{OH} , High Level Output Voltage	R _{LOAD} =1MΩ	0.9*VLOGIC			V	2
V _{OL1} , LOW-Level Output Voltage	R _{LOAD} =1MΩ			0.1*VLOGIC	V	2
V _{OL,INT1} , INT Low-Level Output Voltage	OPEN=1, 0.3mA sink current			0.1	V	2
Output Leakage Current	OPEN=1		100		nA	4
t _{INT} , INT Pulse Width	LATCH_INT_EN=0		50		µs	4
DIGITAL OUPUT (CLKOUT)						
V _{OH} , High Level Output Voltage	R _{LOAD} =1MΩ	0.9*VDD			V	2
V _{OL1} , Low Level Output Voltage	R _{LOAD} =1MΩ			0.1*VDD	V	2

Notes:

1. Tested in production
2. Based on characterization of 30 parts over temperature on evaluation board or in socket
3. Typical. Randomly selected part measured at room temperature on evaluation board or in socket
4. Based on characterization of 5 parts over temperature
5. Refer to Section 4.4 for the recommended power-on procedure



3.3 Electrical Specifications, continued

Typical Operating Circuit of Section 4.2, VDD = 2.5V, VLOGIC = 2.5V, TA=25°C.

Parameters	Conditions	Typical	Units	Notes
Primary I²C I/O (SCL, SDA)				
V _{IL} , LOW-Level Input Voltage		-0.5V to 0.3*VLOGIC	V	1
V _{IH} , HIGH-Level Input Voltage		0.7*VLOGIC to VLOGIC + 0.5V	V	1
V _{hys} , Hysteresis		0.1*VLOGIC	V	1
V _{OL1} , LOW-Level Output Voltage	3mA sink current	0 to 0.4	V	1
I _{OL} , LOW-Level Output Current	V _{OL} = 0.4V	3	mA	1
	V _{OL} = 0.6V	5	mA	1
Output Leakage Current		100	nA	2
t _{of} , Output Fall Time from V _{IHmax} to V _{ILmax}	C _b bus capacitance in pF	20+0.1Cb to 250	ns	1
C _i , Capacitance for Each I/O pin		< 10	pF	
Secondary I²C I/O (AUX_CL, AUX_DA)				
AUX_VDDIO=0				
V _{IL} , LOW-Level Input Voltage		-0.5V to 0.3*VLOGIC	V	1
V _{IH} , HIGH-Level Input Voltage		0.7*VLOGIC to VLOGIC + 0.5V	V	
V _{hys} , Hysteresis		0.1*VLOGIC	V	
V _{OL1} , LOW-Level Output Voltage	VLOGIC > 2V; 1mA sink current	0 to 0.4	V	1
V _{OL3} , LOW-Level Output Voltage	VLOGIC < 2V; 1mA sink current	0 to 0.2*VLOGIC	V	1
I _{OL} , LOW-Level Output Current	V _{OL} = 0.4V	1	mA	1
	V _{OL} = 0.6V	1	mA	1
Output Leakage Current		100	nA	2
t _{of} , Output Fall Time from V _{IHmax} to V _{ILmax}	C _b bus capacitance in pF	20+0.1Cb to 250	ns	1
C _i , Capacitance for Each I/O pin		< 10	pF	
Secondary I²C I/O (AUX_CL, AUX_DA)				
AUX_VDDIO=1				
V _{IL} , LOW-Level Input Voltage		-0.5 to 0.3*VDD	V	1
V _{IH} , HIGH-Level Input Voltage		0.7*VDD to VDD+0.5V	V	1
V _{hys} , Hysteresis		0.1*VDD	V	
V _{OL1} , LOW-Level Output Voltage	1mA sink current	0 to 0.4	V	1
I _{OL} , LOW-Level Output Current	V _{OL} = 0.4V	1	mA	1
	V _{OL} = 0.6V	1	mA	1
Output Leakage Current		100	nA	2
t _{of} , Output Fall Time from V _{IHmax} to V _{ILmax}	C _b bus capacitance in pF	20+0.1Cb to 250	ns	1
C _i , Capacitance for Each I/O pin		< 10	pF	

Notes:

1. Based on characterization of 5 parts over temperature
2. Typical. Randomly selected part measured at room temperature on evaluation board or in socket



3.4 Electrical Specifications, continued

Typical Operating Circuit of Section 4.2, VDD = 2.5V, VLOGIC = 2.5V, T_A=25°C.

Parameters	Conditions	Min	Typical	Max	Units	Notes
INTERNAL CLOCK SOURCE						
Sample Rate, Fast	CLKSEL=0,1,2,3 DLPFCFG=0 SAMPLERATEDIV = 0		8		kHz	3
Sample Rate, Slow	DLPFCFG=1,2,3,4,5, or 6 SAMPLERATEDIV = 0		1		kHz	3
Reference Clock Output	CLKOUTEN = 1		1.024		MHz	3
Clock Frequency Initial Tolerance	CLKSEL=0, 25°C	-5		+5	%	1
	CLKSEL=1,2,3; 25°C	-1		+1	%	1
Frequency Variation over Temperature	CLKSEL=0		-15 to +10		%	2
	CLKSEL=1,2,3		±1		%	2
PLL Settling Time	CLKSEL=1,2,3		1		ms	
EXTERNAL 32.768kHz CLOCK						
External Clock Frequency	CLKSEL=4		32.768		kHz	
External Clock Jitter	Cycle-to-cycle rms		1 to 2		µs	
Sample Rate, Fast	DLPFCFG=0 SAMPLERATEDIV = 0		8.192		kHz	
Sample Rate, Slow	DLPFCFG=1,2,3,4,5, or 6 SAMPLERATEDIV = 0		1.024		kHz	
Reference Clock Output	CLKOUTEN = 1		1.0486		MHz	
PLL Settling Time			1		ms	
EXTERNAL 19.2MHz CLOCK						
External Clock Frequency	CLKSEL=5		19.2		MHz	
Sample Rate, Fast	DLPFCFG=0 SAMPLERATEDIV = 0		8		kHz	
Sample Rate, Slow	DLPFCFG=1,2,3,4,5, or 6 SAMPLERATEDIV = 0		1		kHz	
Reference Clock Output	CLKOUTEN = 1		1.024		MHz	
PLL Settling Time			1		ms	

3.5

Notes:

1. Tested in production
2. Based on characterization of 30 parts over temperature on evaluation board or in socket
3. Typical. Randomly selected part measured at room temperature on evaluation board or in socket

3.6 I²C Timing Characterization

Typical Operating Circuit of Section 4.2, VDD = 2.5V, VLOGIC = 1.8V±5%, 2.5V±5%, 3.0V±5%, or 3.3V±5%, T_A=25°C.

Parameters	Conditions	Min	Typical	Max	Units	Notes
I²C TIMING						
I²C FAST-MODE						
f _{SCL} , SCL Clock Frequency		0		400	kHz	1
t _{HD,STA} , (Repeated) START Condition Hold Time		0.6			µs	1
t _{LOW} , SCL Low Period		1.3			µs	1
t _{HIGH} , SCL High Period		0.6			µs	1
t _{SU,STA} , Repeated START Condition Setup Time		0.6			µs	1
t _{HD,DAT} , SDA Data Hold Time		0			µs	1
t _{SU,DAT} , SDA Data Setup Time		100			ns	1
t _r , SDA and SCL Rise Time	C _b bus cap. from 10 to 400pF	20		300	ns	1
t _f , SDA and SCL Fall Time	C _b bus cap. from 10 to 400pF	20		300	ns	1
t _{SU,STO} , STOP Condition Setup Time		0.6			µs	1
t _{BUF} , Bus Free Time Between STOP and START Condition		1.3			µs	1
C _b , Capacitive Load for each Bus Line			< 400		pF	
t _{VD,DAT} , Data Valid Time				0.9	µs	1
t _{VD,ACK} , Data Valid Acknowledge Time				0.9	µs	1

Notes:

- Based on characterization of 5 parts over temperature on evaluation board or in socket

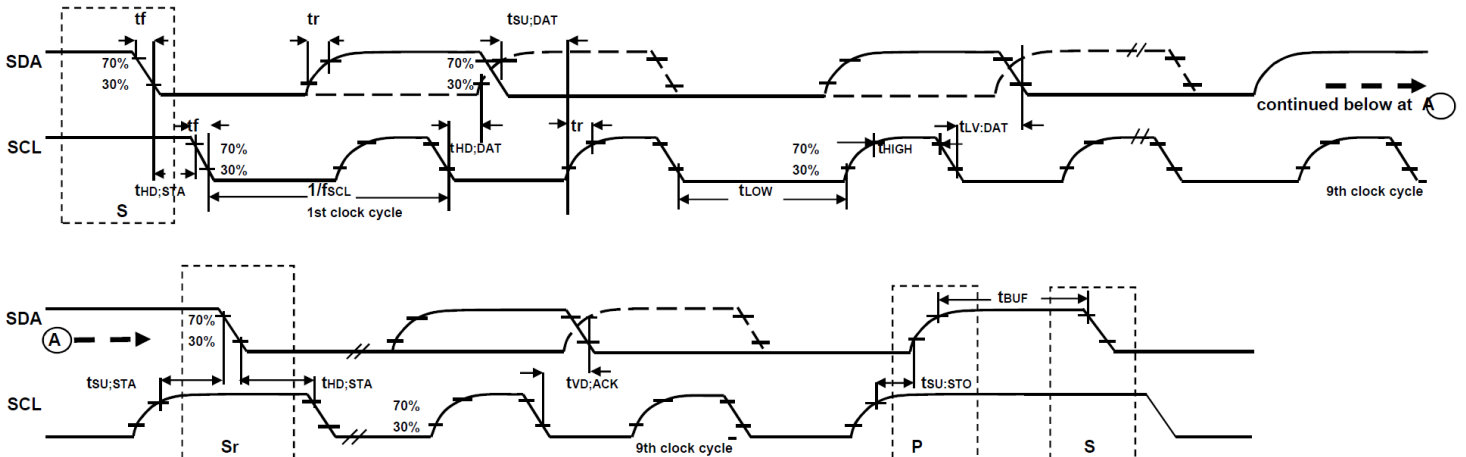

I²C Bus Timing Diagram

3.7 Absolute Maximum Ratings

Stress above those listed as “Absolute Maximum Ratings” may cause permanent damage to the device. These are stress ratings only and functional operation of the device at these conditions is not implied. Exposure to the absolute maximum ratings conditions for extended periods may affect device reliability.

Absolute Maximum Ratings

Parameter	Rating
Supply Voltage, VDD	-0.5V to +6V
VLOGIC Input Voltage Level	-0.5V to VDD + 0.5V
REGOUT	-0.5V to 2V
Input Voltage Level (CLKIN, AUX_DA, AD0, INT, SCL, SDA)	-0.5V to VDD + 0.5V
CPOUT (2.1V ≤ VDD ≤ 3.6V)	-0.5V to 30V
Acceleration (Any Axis, unpowered)	10,000g for 0.3ms
Operating Temperature Range	-40°C to +105°C
Storage Temperature Range	-40°C to +125°C
Electrostatic Discharge (ESD) Protection	1.5kV (HBM); 200V (MM)
Latch-up	JEDEC Class II (2), 125°C Level B, ±60mA

4 Applications Information

4.1 Pin Out and Signal Description

Pin Number	Pin Name	Pin Description
1	CLKIN	External reference clock input. Connect to GND if unused.
6	AUX_DA	Interface to a 3 rd party accelerometer, SDA pin. Logic levels are set to be either VDD or VLOGIC. See Section 6 for more details.
7	AUX_CL	Interface to a 3 rd party accelerometer, SCL pin. Logic levels are set to be either VDD or VLOGIC. See Section 6 for more details.
8	VLOGIC	Digital I/O supply voltage. VLOGIC must be \leq VDD at all times.
9	AD0	I ² C Slave Address LSB
10	REGOUT	Regulator filter capacitor connection
11	RESV-G	Reserved – Connect to Ground.
12	INT	Interrupt digital output (totem pole or open-drain)
13	VDD	Power supply voltage and Digital I/O supply voltage
18	GND	Power supply ground
19	RESV	Reserved. Do not connect.
20	CPOUT	Charge pump capacitor connection
21	RESV	Reserved. Do not connect.
22	CLKOUT	1MHz clock output for third-party accelerometer synchronization
23	SCL	I ² C serial clock
24	SDA	I ² C serial data
2, 3, 4, 5, 14, 15, 16, 17	NC	Not internally connected. May be used for PCB trace routing.

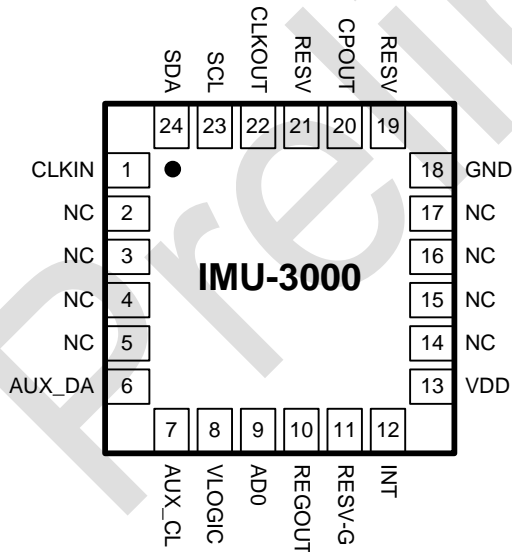

QFN Package (Top View)
 24-pin, 4mm x 4mm x 0.9mm

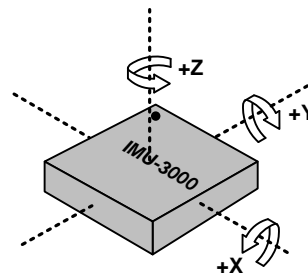

Orientation of Axes of Sensitivity and Polarity of Rotation

4.2 Typical Operating Circuit

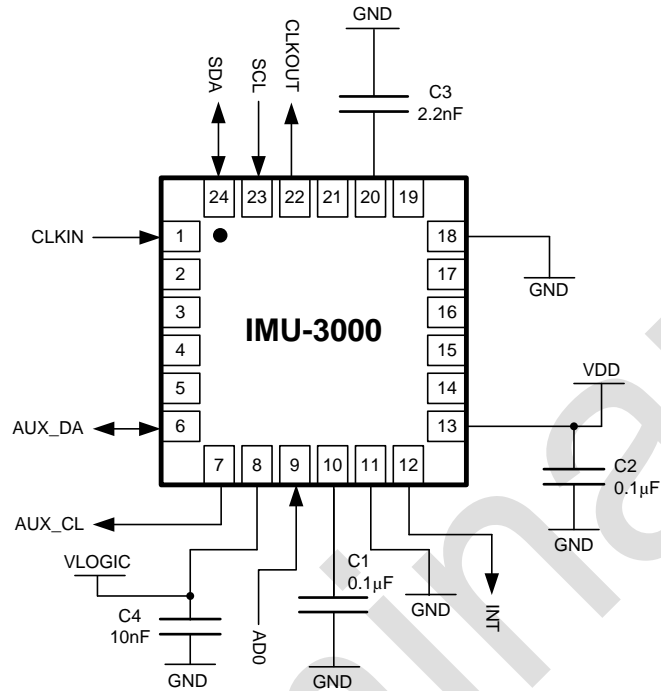

Typical Operating Circuit

4.3 Bill of Materials for External Components

Component	Label	Specification	Quantity
Regulator Filter Capacitor	C1	Ceramic, X7R, 0.1µF ±10%, 2V	1
VDD Bypass Capacitor	C2	Ceramic, X7R, 0.1µF ±10%, 4V	1
Charge Pump Capacitor	C3	Ceramic, X7R, 2.2nF ±10%, 50V	1
VLOGIC Bypass Capacitor	C4	Ceramic, X7R, 10nF ±10%, 4V	1

4.4 Recommended Power-on Procedure

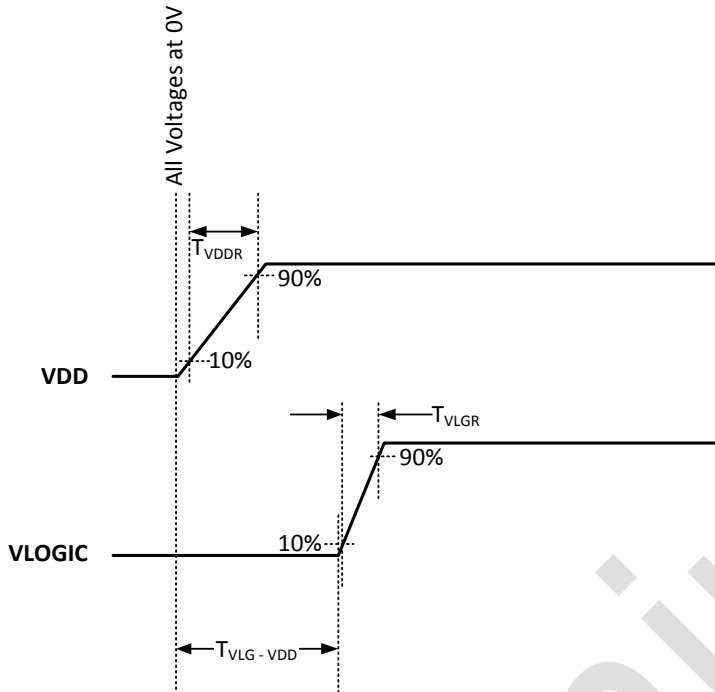

Power-Up Sequencing

1. T_{VDDR} is VDD rise time: Time for VDD to rise from 10% to 90% of its final value
2. T_{VDDR} is $\leq 5ms$
3. T_{VLGR} is VLOGIC rise time: Time for VLOGIC to rise from 10% to 90% of its final value
4. T_{VLGR} is $\leq 1msec$
5. $T_{VLG-VDD}$ is the delay from the start of VDD ramp to the start of VLOGIC rise
6. $T_{VLG-VDD}$ is $\geq 0ms$; VLOGIC amplitude must always be $\leq VDD$ amplitude
7. VDD and VLOGIC must be monotonic ramps

Preliminary

5 Functional Overview

5.1 Block Diagram

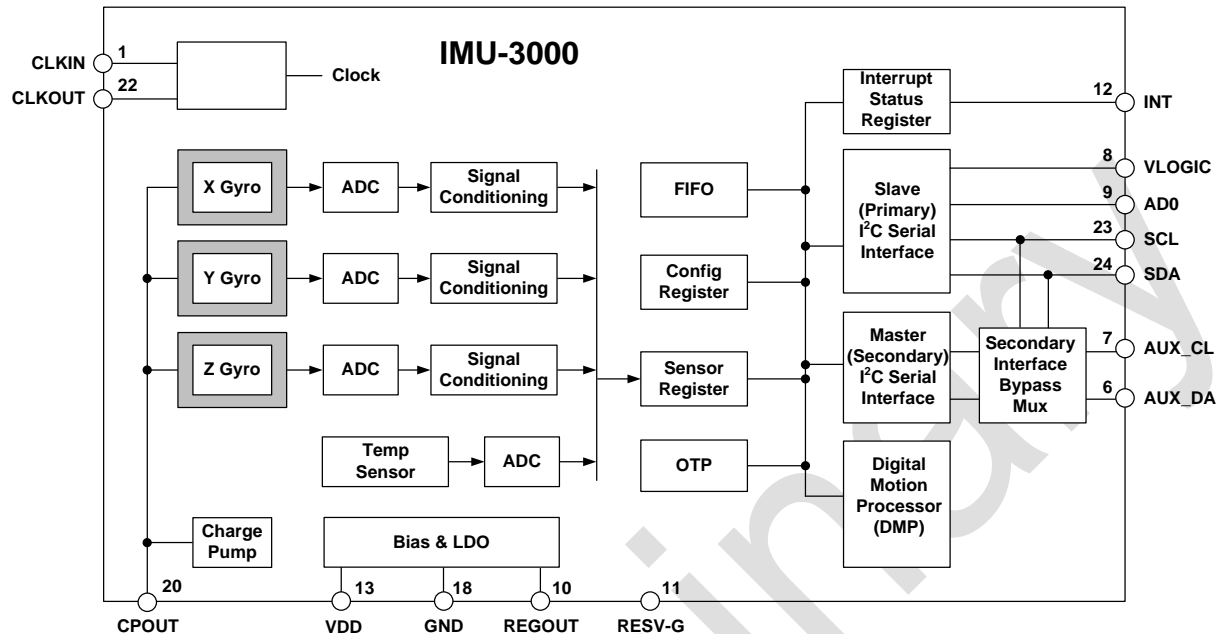

5.2 Overview

The IMU-3000 is comprised of the following key blocks / functions:

- Three-axis MEMS rate gyroscope sensors with 16-bit ADCs and signal conditioning
- Digital Motion Processor (DMP)
- Primary I²C serial communications interface
- Secondary I²C serial interface for 3rd party accelerometer
- Clocking
- Sensor Data Registers
- FIFO
- Interrupts
- Digital-Output Temperature Sensor
- Bias and LDO
- Charge Pump

5.3 Three-Axis MEMS Gyroscope with 16-bit ADCs and Signal Conditioning

The IMU-3000 consists of three independent vibratory MEMS rate gyroscopes, which detect rotation about the X, Y, and Z axes. When the gyros are rotated about any of the sense axes, the Coriolis Effect causes a vibration that is detected by a capacitive pickoff. The resulting signal is amplified, demodulated, and filtered to produce a voltage that is proportional to the angular rate. This voltage is digitized using individual on-chip 16-bit Analog-to-Digital Converters (ADCs) to sample each axis. The full-scale range of the gyro sensors may be digitally programmed to ± 250 , ± 500 , ± 1000 , or ± 2000 degrees per second (dps). ADC sample rate is programmable from 8,000 samples per second, down to 3.9 samples per second, and user-selectable low-pass filters enable a wide range of cut-off frequencies.

5.4 Digital Motion Processor

The embedded Digital Motion Processor (DMP) is located within the IMU-3000 and offloads computation of motion processing algorithms from the host processor. The DMP acquires and processes data from the on-chip gyroscopes and an external accelerometer. The resulting data can be read from IMU-3000's FIFO. The DMP has access to certain of the IMU's external pins, which can be used for synchronizing external devices to the motion sensors, or generating interrupts for the application.

The purpose of the DMP is to offload both timing requirements and processing power from the host processor. Typically, motion processing algorithms should be run at a high rate, often around 200Hz, in order to provide accurate results with low latency. This is required even if the application updates at a much lower rate; for example, a low power user interface may update as slowly as 5Hz, but the motion processing should still run at 200Hz. The DMP can be used as a tool in order to minimize power, simplify timing and software architecture, and save valuable MIPS on the host processor for use in the application.

5.5 Primary I²C Serial Communications Interface

The IMU-3000 communicates to a system processor using the I²C serial interface; the device always acts as a slave when communicating to the system processor. The logic level for communications to the master is set by the voltage on the VLOGIC pin. The LSB of the of the I²C slave address is set by pin 9 (AD0).

I²C protocol is described in more detail in Section 6.

Note: When VDD is low, the primary I²C interface pins become low impedance and thus can load the serial bus. This is a concern if other devices are active on the bus during this time.

5.6 Secondary I²C Serial Interface for Third-Party Accelerometer

The IMU-3000 has a secondary I²C bus for communicating to an off-chip 3-axis digital output accelerometer. This bus has two operating modes: I²C Master Mode, where the IMU-3000 acts as a master to an external accelerometer connected to the secondary I²C bus; and Pass-Through Mode, where the IMU-3000 directly connects the primary and secondary I²C buses together, to allow the system processor to directly communicate with the external accelerometer.

Secondary I²C Bus Modes of Operation:

- **I²C Master Mode:** allows the IMU-3000 to directly access the data registers of an external digital accelerometer. In this mode, the IMU-3000 directly obtains sensor data from an accelerometer thus allowing the on-chip DMP to generate sensor fusion data without intervention from the system applications processor. In I²C master mode, the IMU-3000 can be configured to perform burst reads, returning the following data from the accelerometer:
 - X accelerometer data (2 bytes)
 - Y accelerometer data (2 bytes)
 - Z accelerometer data (2 bytes)
- **Pass-Through Mode:** allows an external system processor to act as master and directly communicate to the external accelerometer connected to the secondary I²C bus pins (AUX_DA and AUX_CL). This is useful for configuring the accelerometer, or for keeping the IMU-3000 in a low-power mode, when only the accelerometer is to be used. In this mode, the secondary I²C bus control logic (third-party accelerometer Interface block) of the IMU-3000 is disabled, and the secondary I²C pins AUX_DA and AUX_CL (Pins 6 and 7) are connected to the main I²C bus (Pins 23 and 24) through analog switches.

In the Pass-Through Mode the system processor can still access MPU-30X0 gyro data through the I²C interface.

Secondary I²C Bus I/O Logic Levels

The logic levels of the secondary I²C bus can be programmed to be either VDD or VLOGIC (see Section 7).

Secondary I²C Bus Internal Pull-up Configuration

- I²C Master Mode Equivalent Circuit:** The simplified equivalent circuit diagram below shows the IMU-3000 auxiliary I²C interface while in master mode. It should be noted that the AUX_CL pin is output only and is driven by a CMOS output buffer which does not require a pull-up resistor. The AUX_DA pin is open drain and an internal pull-up resistor is enabled. The CMOS output buffer and the pull up resistor can be powered from VDD or VLOGIC. Please refer to Section 7.2 for more details.

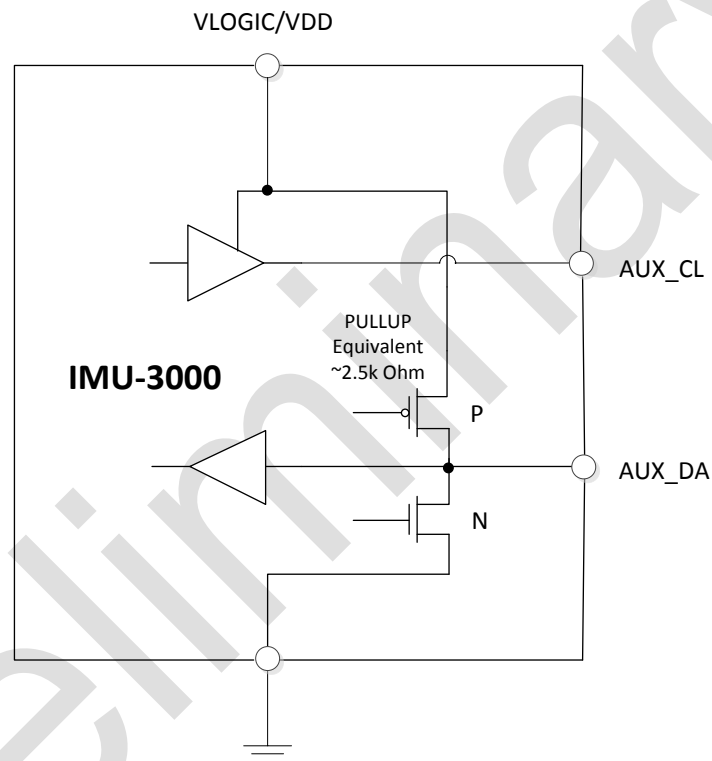

IMU-3000 I²C Master Mode Auxiliary I²C interface – equivalent circuit

- Pass-Through Mode – Equivalent Circuit: The simplified equivalent circuit diagram below shows the IMU-3000 I²C interface during pass-through mode. Internal analog switches are used to connect the primary and auxiliary I²C interfaces together (SCL to AUX_CL through a buffer and SDA to AUX_DA pins through a level shifter).

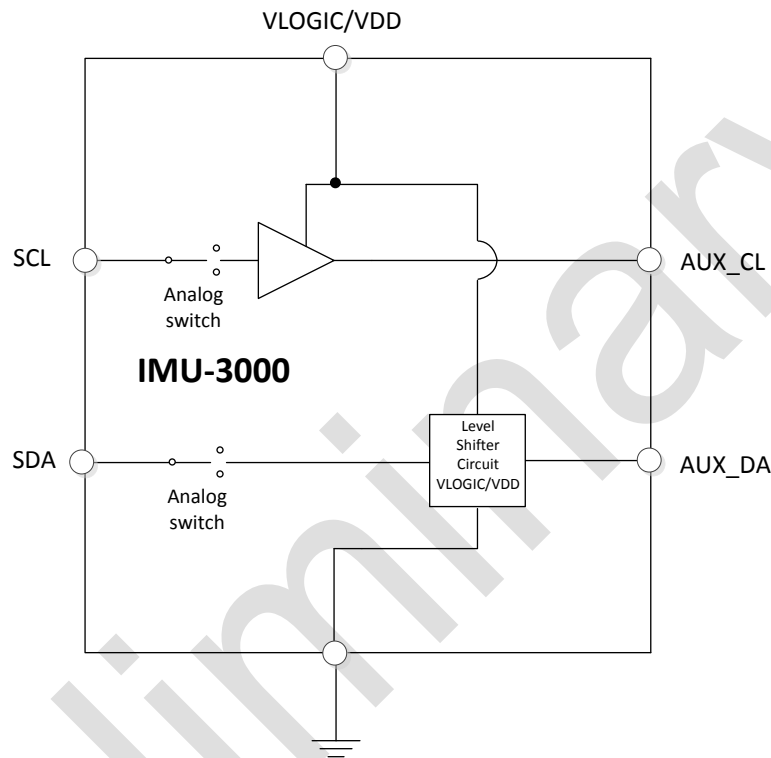

IMU-3000 Pass-Through Mode Equivalent Circuit

5.7 Internal Clock Generation

The IMU-3000 has a flexible clocking scheme, allowing for a variety of internal or external clock sources for the internal synchronous circuitry. This synchronous circuitry includes the signal conditioning and ADCs, the DMP, and various control circuits and registers. An on-chip PLL provides flexibility in the allowable inputs for generating this clock.

Allowable internal sources for generating the internal clock are:

- An internal relaxation oscillator
- Any of the X, Y, or Z gyros (MEMS oscillators with a variation of $\pm 1\%$ over temperature range)

Allowable external clocking sources are:

- 32.768kHz square wave
- 19.2MHz square wave

Which source to select for generating the internal synchronous clock depends on the availability of external sources and the requirements for power consumption and clock accuracy. Most likely, these requirements will vary by mode of operation. For example, in one mode, where the biggest concern is power consumption, one may wish to operate the Digital Motion Processor of the IMU-3000 to process accelerometer data, while

keeping the gyros off. In this case, the internal relaxation oscillator is a good clock choice. However, in another mode, where the gyros are active, selecting the gyros as the clock source provides for a more-accurate clock source.

Clock accuracy is important, since timing errors directly affect the distance and angle calculations performed by the Digital Motion Processor (or by extension, by any processor).

There are also start-up conditions to consider. When the IMU-3000 first starts up, the device operates off of its internal clock, until programmed to operate from another source. This allows the user, for example, to wait for the MEMS oscillators to stabilize before they are selected as the clock source.

5.8 Clock Output

In addition, the IMU-3000 provides a clock output, which allows the device to operate synchronously with an external digital 3-axis accelerometer. Operating synchronously provides for higher-quality sensor fusion data, since the sampling instant for the sensor data can be set to be coincident for all sensors.

5.9 Sensor Data Registers

The sensor data registers contain the latest gyro and temperature data. They are read-only registers, and are accessed via the Serial Interface. Data from these registers may be read anytime, however, the interrupt function may be used to determine when new data is available.

5.10 FIFO

The IMU-3000 contains a 512-byte FIFO register that is accessible via the Serial Interface. The FIFO configuration register determines what data goes into it, with possible choices being gyro data, accelerometer data, temperature readings, and auxiliary ADC readings. A FIFO counter keeps track of how many bytes of valid data are contained in the FIFO. The FIFO register supports burst reads. The interrupt function may be used to determine when new data is available.

5.11 Interrupts

Interrupt functionality is configured via the Interrupt Configuration register. Items that are configurable include the INT pin configuration, the interrupt latching and clearing method, and triggers for the interrupt. Items that can trigger an interrupt are (1) Clock generator locked to new reference oscillator (used when switching clock sources); (2) Digital Motion Processor Done (programmable function); (3) new data is available to be read (from the FIFO and Data registers); and (4) the IMU-3000 did not receive an acknowledge from the accelerometer on the Secondary I²C bus. The interrupt status can be read from the Interrupt Status register.

5.12 Digital-Output Temperature Sensor

An on-chip temperature sensor and ADC are used to measure the IMU-3000 die temperature. The readings from the ADC can be read from the FIFO or the Sensor Data registers.

5.13 Bias and LDO

The bias and LDO section generates the internal supply and the reference voltages and currents required by the IMU-3000. Its inputs are an unregulated VDD of 2.1V to 3.6V and a VLOGIC - logic reference supply voltage - of 1.71V to VDD. The LDO output is bypassed by a 0.1µF capacitor at REGOUT.

5.14 Charge Pump

An on-board charge pump generates the high voltage required for the MEMS oscillators. Its output is bypassed by a 2.2nF capacitor at CPOUT.

6 Digital Interface

6.1 I²C Serial Interface

The internal registers of the IMU-3000 can be accessed using I²C at up to 400kHz.

Serial Interface

Pin Number	Pin Name	Pin Description
8	VLOGIC	Digital I/O supply voltage. VLOGIC must be ≤ VDD at all times.
9	AD0	I ² C Slave Address LSB
23	SCL	I ² C serial clock
24	SDA	I ² C serial data

6.1.1 I²C Interface

I²C is a two-wire interface comprised of the signals serial data (SDA) and serial clock (SCL). In general, the lines are open-drain and bi-directional. In a generalized I²C interface implementation, attached devices can be a master or a slave. The master device puts the slave address on the bus, and the slave device with the matching address acknowledges the master.

The IMU-3000 always operates as a slave device when communicating to the system processor, which thus acts as the master. SDA and SCL lines typically need pull-up resistors to VDD. The maximum bus speed is 400kHz.

The slave address of the IMU-3000 is b110100X which is 7 bits long. The LSB bit of the 7 bit address is determined by the logic level on pin ADO. This allows two IMU-3000s to be connected to the same I²C bus. When used in this configuration, the address of the one of the devices should be b1101000 (pin ADO is logic low) and the address of the other should be b1101001 (pin ADO is logic high). The I²C address is stored in the WHO_AM_I register.

I²C Communications Protocol

START (S) and STOP (P) Conditions

Communication on the I²C bus starts when the master puts the START condition (S) on the bus, which is defined as a HIGH-to-LOW transition of the SDA line while SCL line is HIGH (see figure below). The bus is considered to be busy until the master puts a STOP condition (P) on the bus, which is defined as a LOW to HIGH transition on the SDA line while SCL is HIGH (see figure below).

Additionally, the bus remains busy if a repeated START (Sr) is generated instead of a STOP condition.

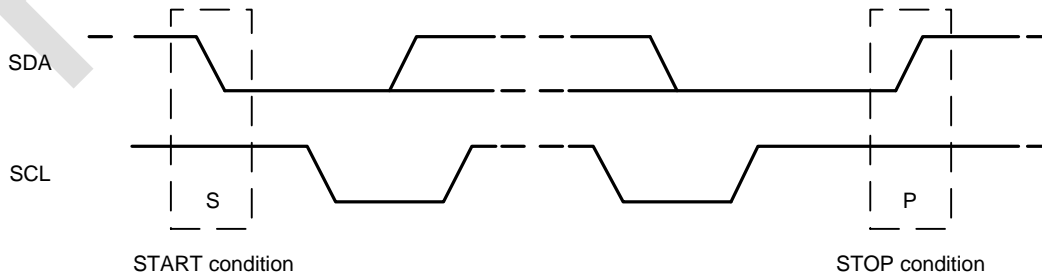

START and STOP Conditions

Data Format / Acknowledge

I²C data bytes are defined to be 8 bits long. There is no restriction to the number of bytes transmitted per data transfer. Each byte transferred must be followed by an acknowledge (ACK) signal. The clock for the acknowledge signal is generated by the master, while the receiver generates the actual acknowledge signal by pulling down SDA and holding it low during the HIGH portion of the acknowledge clock pulse.

If a slave is busy and cannot transmit or receive another byte of data until some other task has been performed, it can hold SCL LOW, thus forcing the master into a wait state. Normal data transfer resumes when the slave is ready, and releases the clock line (refer to the following figure).

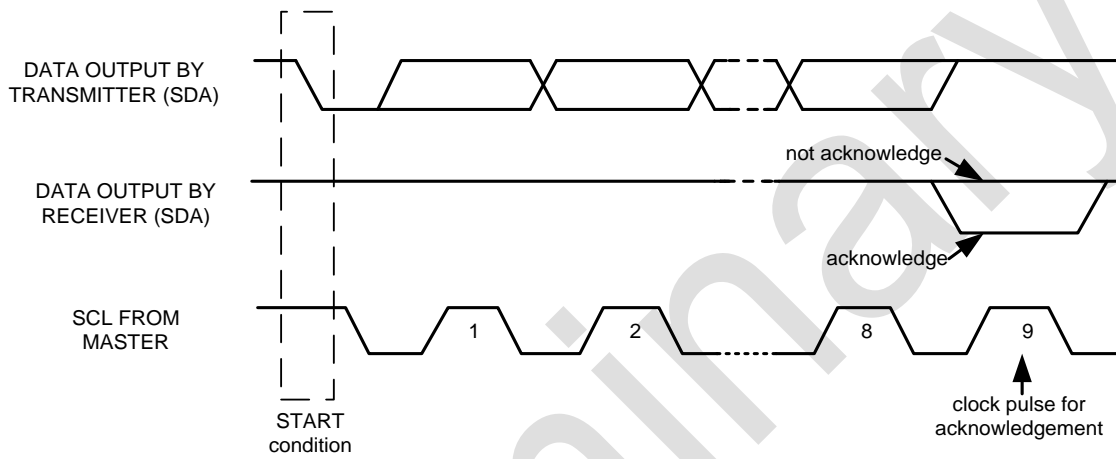

Acknowledge on the I²C Bus

Communications

After beginning communications with the START condition (S), the master sends a 7-bit slave address followed by an 8th bit, the read/write bit. The read/write bit indicates whether the master is receiving data from or is writing to the slave device. Then, the master releases the SDA line and waits for the acknowledge signal (ACK) from the slave device. Each byte transferred must be followed by an acknowledge bit. To acknowledge, the slave device pulls the SDA line LOW and keeps it LOW for the high period of the SCL line. Data transmission is always terminated by the master with a STOP condition (P), thus freeing the communications line. However, the master can generate a repeated START condition (Sr), and address another slave without first generating a STOP condition (P). A LOW to HIGH transition on the SDA line while SCL is HIGH defines the stop condition. All SDA changes should take place when SCL is low, with the exception of start and stop conditions.

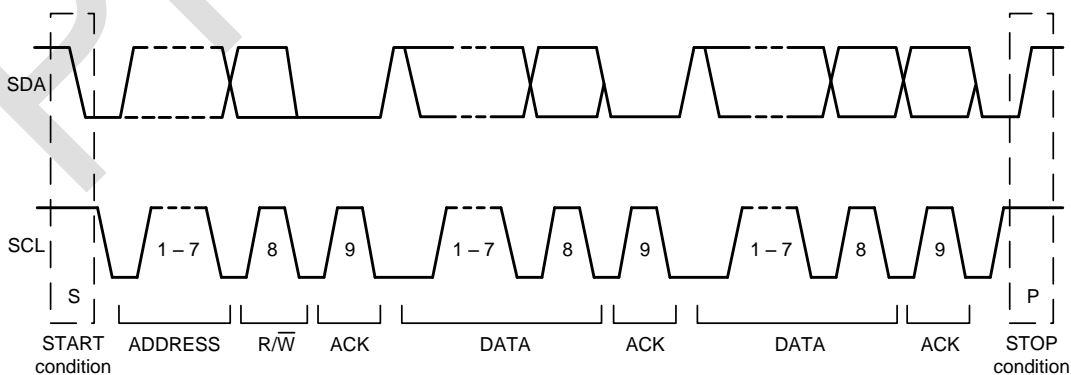

Complete I²C Data Transfer

To write the internal IMU-3000 registers, the master transmits the start condition (S), followed by the I²C address and the write bit (0). At the 9th clock cycle (when the clock is high), the IMU-3000 acknowledges the transfer. Then the master puts the register address (RA) on the bus. After the IMU-3000 acknowledges the reception of the register address, the master puts the register data onto the bus. This is followed by the ACK signal, and data transfer may be concluded by the stop condition (P). To write multiple bytes after the last ACK signal, the master can continue outputting data rather than transmitting a stop signal. In this case, the IMU-3000 automatically increments the register address and loads the data to the appropriate register. The following figures show single and two-byte write sequences.

Single-Byte Write Sequence

Master	S	AD+W		RA		DATA		P
Slave			ACK		ACK		ACK	

Burst Write Sequence

Master	S	AD+W		RA		DATA		DATA		P
Slave			ACK		ACK		ACK		ACK	

To read the internal IMU-3000 registers, the master sends a start condition, followed by the I²C address and a write bit, and then the register address that is going to be read. Upon receiving the ACK signal from the IMU-3000, the master transmits a start signal followed by the slave address and read bit. As a result, the IMU-3000 sends an ACK signal and the data. The communication ends with a not acknowledge (NACK) signal and a stop bit from master. The NACK condition is defined such that the SDA line remains high at the 9th clock cycle. The following figures show single and two-byte read sequences.

Single-Byte Read Sequence

Master	S	AD+W		RA		S	AD+R			NACK	P
Slave			ACK		ACK			ACK	DATA		

Burst Read Sequence

Master	S	AD+W		RA		S	AD+R			ACK		NACK	P
Slave			ACK		ACK			ACK	DATA		DATA		

I²C Terms

Signal	Description
S	Start Condition: SDA goes from high to low while SCL is high
AD	Slave I ² C address
W	Write bit (0)
R	Read bit (1)
ACK	Acknowledge: SDA line is low while the SCL line is high at the 9 th clock cycle
NACK	Not-Acknowledge: SDA line stays high at the 9 th clock cycle
RA	IMU-3000 internal register address
DATA	Transmit or received data
P	Stop condition: SDA going from low to high while SCL is high

7 Serial Interface Considerations

7.1 Supported Interfaces

The IMU-3000 supports I²C communications on both its primary (microprocessor) serial interface and its secondary (accelerometer) interface.

7.2 Logic Levels

The IMU-3000 accelerometer bus I/O logic levels are set to be either VDD or VLOGIC, as shown in the table below.

I/O Logic Levels vs. *AUX_VDDIO* bit

<i>AUX_VDDIO</i>	MICROPROCESSOR LOGIC LEVELS (Pins: SDA, SCL, AD0, CLKIN, INT)	ACCELEROMETER LOGIC LEVELS (Pins: AUX_DA, AUX_CL)
0	VLOGIC	VLOGIC
1	VLOGIC	VDD

Notes:

1. CLKOUT has logic levels that are always referenced to VDD
2. The power-on-reset value for *AUX_VDDIO* is 0.

VLOGIC may be set to be equal to VDD or to another voltage, such that at all times VLOGIC is \leq VDD. When *AUX_VDDIO* is set to 0 (its power-on-reset value), VLOGIC is the reference voltage for both the microprocessor system bus and the accelerometer secondary bus, as shown in the figure of Section 8.2.1. When *AUX_VDDIO* is set to 1, VLOGIC is the reference voltage for the microprocessor system bus and VDD is the reference voltage for the accelerometer secondary bus, as shown in the figure of Section 8.2.2.

7.2.1 AUX_VDDIO = 0

The figure below shows logic levels and voltage connections for AUX_VDDIO = 0. Note that the actual configuration will depend on the type of third-party accelerometer used.

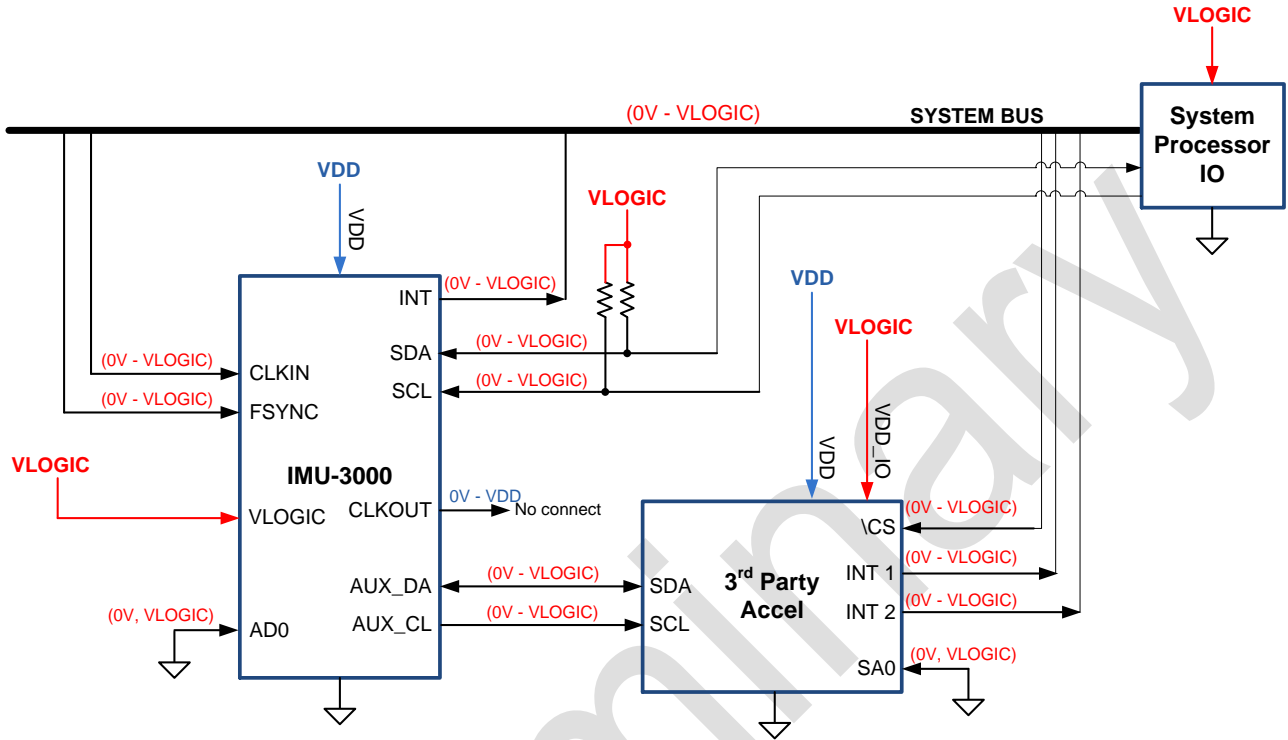

Notes:

1. The AUX_VDDIO register bit determines the I/O voltage levels of AUX_DA and AUX_CL (0 = set output levels relative to VLOGIC)
2. CLKOUT is always referenced to VDD
3. Other IMU-3000 logic I/O are always referenced to VLOGIC

I/O Levels and Connections for AUX_VDDIO = 0

7.2.2 AUX_VDDIO = 1

When *AUX_VDDIO* is set to 1 by the user, *VLOGIC* is the reference voltage for the microprocessor system bus and *VDD* is the reference voltage for the accelerometer secondary bus, as shown in the figure below. This is useful when interfacing to a third-party accelerometer where there is only one supply for both the logic and analog sections of the 3rd party accelerometer.

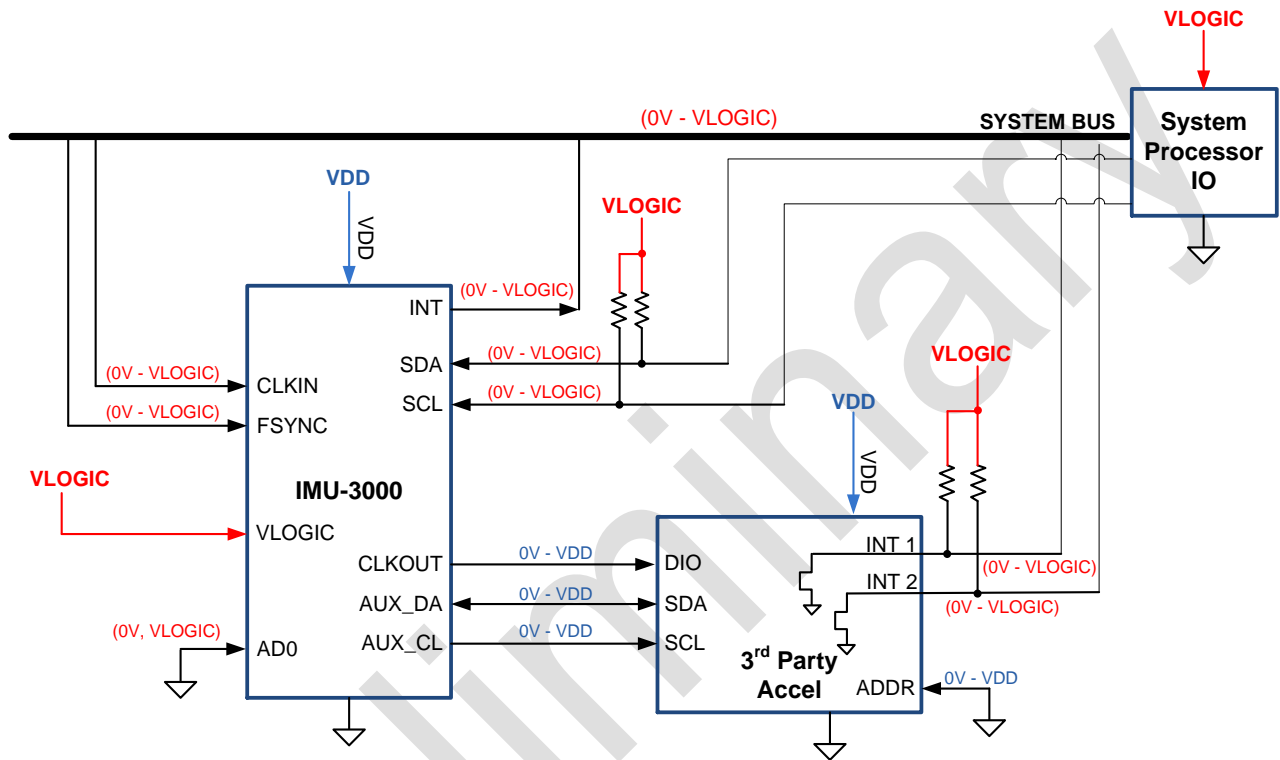

Voltage/ Configuration	Configuration 1	Configuration 2
VLOGIC	1.8V±5%	3.0V±5%
VDD	2.5V±5%	3.0V±5%
AUX_VDDIO	1	1

Notes:

1. The *AUX_VDDIO* register bit determines the I/O voltage levels of *AUX_DA* and *AUX_CL* (1 = set output levels relative to *VDD*)
2. *CLKOUT* is always referenced to *VDD*
3. Other IMU-3000 logic I/O are always referenced to *VLOGIC*
4. If third-party accelerometer logic levels are referenced to *VDD*; setting *INT1* and *INT2* to open-drain configuration provides voltage compatibility when *VDD* ≠ *VLOGIC*.
 When *VDD* = *VLOGIC*, *INT1* and *INT2* may be set to push-pull outputs, and the external pull-up resistors will not be needed.

I/O Levels and Connections for Two Example Power Configurations (*AUX_VDDIO* = 1)

8 Assembly

This section provides general guidelines for assembling InvenSense Micro Electro-Mechanical Systems (MEMS) gyros packaged in Quad Flat No leads package (QFN) surface mount integrated circuits.

8.1 Orientation of Axes

The diagram below shows the orientation of the axes of sensitivity and the polarity of rotation. Note the pin 1 identifier in the figure.

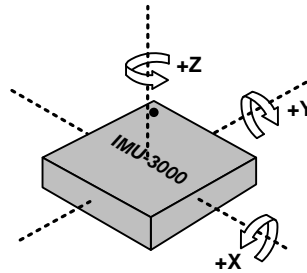

Orientation of Axes of Sensitivity and Polarity of Rotation

8.2 Package Dimensions

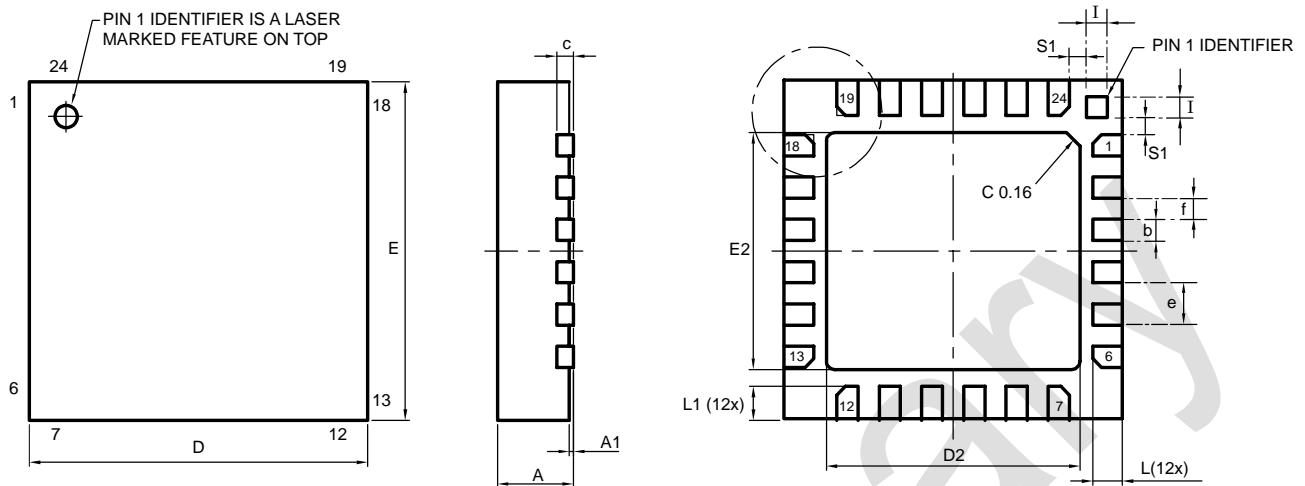

SYMBOLS	DIMENSIONS IN MILLIMETERS		
	MIN	NOM	MAX
A	0.85	0.90	0.95
A1	0.00	0.02	0.05
b	0.18	0.25	0.30
c	---	0.20 REF.	---
D	3.90	4.00	4.10
D2	2.95	3.00	3.05
E	3.90	4.00	4.10
E2	2.75	2.80	2.85
e	---	0.50	---
f (e-b)	0.20	0.25	0.32
L	0.30	0.35	0.40
L1	0.35	0.40	0.45
l	0.20	0.25	0.30
R	0.05	---	0.10
s	0.05	---	0.15
S1	0.15	0.20	0.25

8.3 PCB Design Guidelines

The Pad Diagram using a JEDEC type extension with solder rising on the outer edge is shown below. The Pad Dimensions Table shows pad sizing (mean dimensions) recommended for the IMU-3000 product.

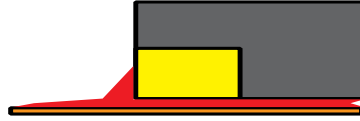

JEDEC type extension with solder rising on outer edge

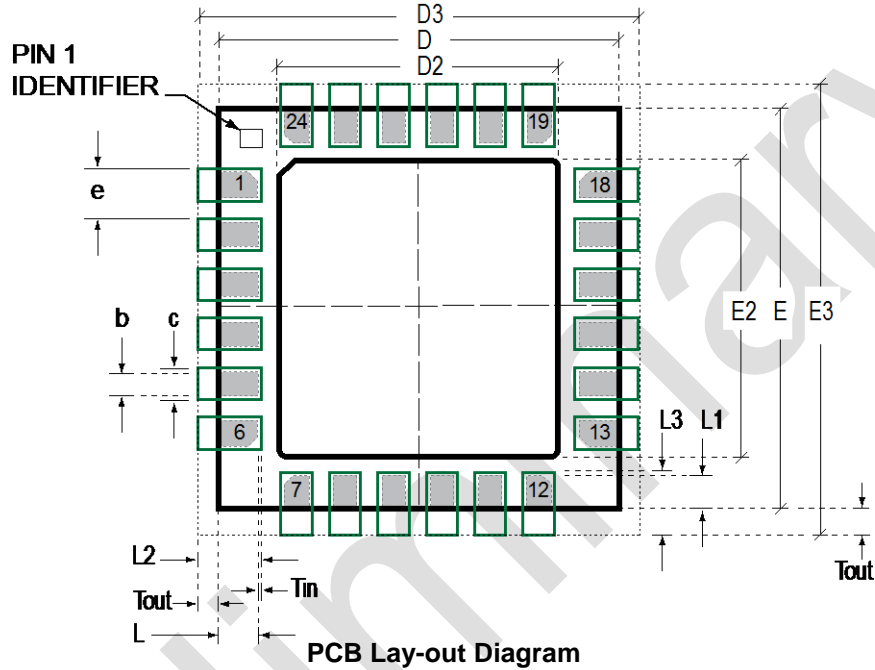

SYMBOLS	DIMENSIONS IN MILLIMETERS	NOM
Nominal Package I/O Pad Dimensions		
e	Pad Pitch	0.50
b	Pad Width	0.25
L	Pad Length	0.35
L1	Pad Length	0.40
D	Package Width	4.00
E	Package Length	4.00
D2	Exposed Pad Width	3.00
E2	Exposed Pad Length	2.80
I/O Land Design Dimensions (Guidelines)		
D3	I/O Pad Extent Width	4.80
E3	I/O Pad Extent Length	4.80
c	Land Width	0.35
Tout	Outward Extension	0.40
Tin	Inward Extension	0.05
L2	Land Length	0.80
L3	Land Length	0.85

PCB Dimensions Table (for PCB Lay-out Diagram)

8.4 Assembly Precautions

8.4.1 Gyroscope Surface Mount Guidelines

InvenSense MEMS Gyros sense rate of rotation. In addition, gyroscopes sense mechanical stress coming from the printed circuit board (PCB). This PCB stress can be minimized by adhering to certain design rules:

When using MEMS gyroscope components in plastic packages, PCB mounting and assembly can cause package stress. This package stress in turn can affect the output offset and its value over a wide range of temperatures. This stress is caused by the mismatch between the Coefficient of Linear Thermal Expansion (CTE) of the package material and the PCB. Care must be taken to avoid package stress due to mounting.

Traces connected to pads should be as symmetric as possible. Maximizing symmetry and balance for pad connection will help component self alignment and will lead to better control of solder paste reduction after reflow.

Any material used in the surface mount assembly process of the MEMS gyroscope should be free of restricted RoHS elements or compounds. Pb-free solders should be used for assembly.

8.4.2 Exposed Die Pad Precautions

The IMU-3000 has very low active and standby current consumption. The exposed die pad is not required for heat sinking, and should not be soldered to the PCB. Failure to adhere to this rule can induce performance changes due to package thermo-mechanical stress. There is no electrical connection between the pad and the CMOS.

8.4.3 Trace Routing

Routing traces or vias under the gyro package such that they run under the exposed die pad is prohibited. Routed active signals may harmonically couple with the gyro MEMS devices, compromising gyro response. These devices are designed with the drive frequencies as follows: $X = 33 \pm 3\text{kHz}$, $Y = 30 \pm 3\text{kHz}$, and $Z = 27 \pm 3\text{kHz}$. To avoid harmonic coupling don't route active signals in non-shielded signal planes directly below, or above the gyro package. Note: For best performance, design a ground plane under the e-pad to reduce PCB signal noise from the board on which the gyro device is mounted. If the gyro device is stacked under an adjacent PCB board, design a ground plane directly above the gyro device to shield active signals from the adjacent PCB board.

8.4.4 Component Placement

Do not place large insertion components such as keyboard or similar buttons, connectors, or shielding boxes at a distance of less than 6 mm from the MEMS gyro. Maintain generally accepted industry design practices for component placement near the IMU-3000 to prevent noise coupling and thermo-mechanical stress.

8.4.5 PCB Mounting and Cross-Axis Sensitivity

Orientation errors of the gyroscope mounted to the printed circuit board can cause cross-axis sensitivity in which one gyro responds to rotation about another axis. For example, the X-axis gyroscope may respond to rotation about the Y or Z axes. The orientation mounting errors are illustrated in the figure below.

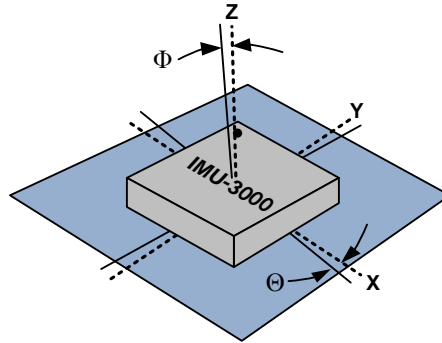

Package Gyro Axes (- - -) Relative to PCB Axes (—) with Orientation Errors (Θ and Φ)

The table below shows the cross-axis sensitivity of the gyroscope for a given orientation error.

Cross-Axis Sensitivity vs. Orientation Error

Orientation Error (θ or Φ)	Cross-Axis Sensitivity (sinθ or sinΦ)
0°	0%
0.5°	0.87%
1°	1.75%

The specification for cross-axis sensitivity in Section 3.1 includes the effect of the die orientation error with respect to the package.

8.4.6 MEMS Handling Instructions

MEMS (Micro Electro-Mechanical Systems) are a time-proven, robust technology used in hundreds of millions of consumer, automotive and industrial products. MEMS devices consist of microscopic moving mechanical structures. They differ from conventional IC products, even though they can be found in similar packages. Therefore, MEMS devices require different handling precautions than conventional ICs prior to mounting onto printed circuit boards (PCBs).

The IMU-3000 gyroscope has been qualified to a shock tolerance of 10,000g. InvenSense packages its gyroscopes as it deems proper for protection against normal handling and shipping. It recommends the following handling precautions to prevent potential damage.

- Do not drop individually packaged gyroscopes, or trays of gyroscopes onto hard surfaces. Components placed in trays could be subject to g-forces in excess of 10,000g if dropped.
- Printed circuit boards that incorporate mounted gyroscopes should not be separated by manually snapping apart. This could also create g-forces in excess of 10,000g.

8.4.7 ESD Considerations

Establish and use ESD-safe handling precautions when unpacking and handling ESD-sensitive devices.

- Store ESD sensitive devices in ESD safe containers until ready for use. The Tape-and-Reel moisture-sealed bag is an ESD approved barrier. The best practice is to keep the units in the original moisture sealed bags until ready for assembly.
- Restrict all device handling to ESD protected work areas that measure less than 200V static charge. Ensure that all workstations and personnel are properly grounded to prevent ESD.

8.5 Reflow Specification

Qualification Reflow: The IMU-3000 was qualified in accordance with IPC/JEDEC J-STD-020D.01. This standard classifies proper packaging, storage and handling in order to avoid subsequent thermal and mechanical damage during the solder reflow attachment phase of assembly. The classification specifies a sequence consisting of a bake cycle, a moisture soak cycle in a temperature humidity oven, followed by three solder reflow cycles and functional testing for qualification. All temperatures refer to the topside of the QFN package, as measured on the package body surface. The peak solder reflow classification temperature requirement is (260 +5/-0°C) for lead-free soldering of components measuring less than 1.6 mm in thickness.

Production Reflow: Check the recommendations of your solder manufacturer. For optimum results, production solder reflow processes should reduce exposure to high temperatures, and use lower ramp-up and ramp-down rates than those used in the component qualification profile shown for reference below.

Production reflow should never exceed the maximum constraints listed in the table and shown in the figure below. These constraints were used for the qualification profile, and represent the maximum tolerable ratings for the device.

Maximum Temperature IR / Convection Solder Reflow Curve Used for Qualification

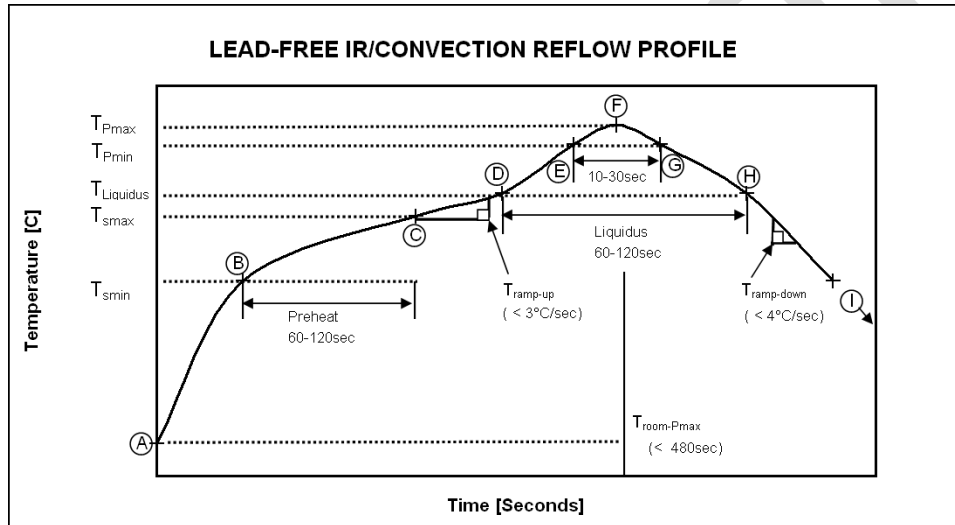

Temperature Set Points for IR / Convection Reflow Corresponding to Figure Above

Step	Setting	CONSTRAINTS		
		Temp (°C)	Time (sec)	Rate (°C/sec)
A	T _{room}	25		
B	T _{Smin}	150		
C	T _{Smax}	200	60 < t _{BC} < 120	
D	T _{Liquidus}	217		Γ(T _{Liquidus} -T _{Pmax}) < 3
E	T _{Pmin} [255°C, 260°C]	255		Γ(T _{Liquidus} -T _{Pmax}) < 3
F	T _{Pmax} [260°C, 265°C]	260	t _{AF} < 480	Γ(T _{Liquidus} -T _{Pmax}) < 3
G	T _{Pmin} [255°C, 260°C]	255	10 < t _{EG} < 30	Γ(T _{Pmax} -T _{Liquidus}) < 4
H	T _{Liquidus}	217	60 < t _{DH} < 120	
I	T _{room}	25		

Note: For users T_{Pmax} must not exceed the classification temperature (260°C).
 For suppliers T_{Pmax} must equal or exceed the classification temperature.

8.6 Storage Specifications

The storage specification of the IMU-3000 gyroscope conforms to IPC/JEDEC J-STD-020C Moisture Sensitivity Level (MSL) 3.

Storage Specifications for IMU-3000

Calculated shelf-life in moisture-sealed bag	12 months -- Storage conditions: <40°C and <90% RH
After opening moisture-sealed bag	168 hours -- Storage conditions: ambient ≤30°C at 60% RH

8.7 Package Marking Specification

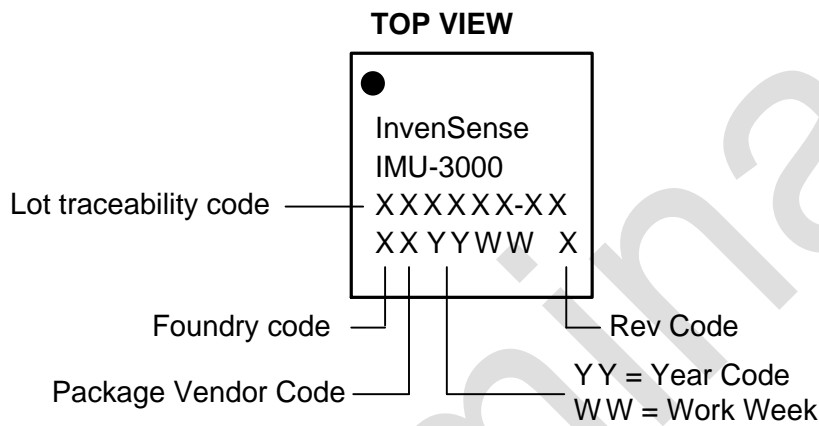

Package Marking Specification

8.8 Tape & Reel Specification

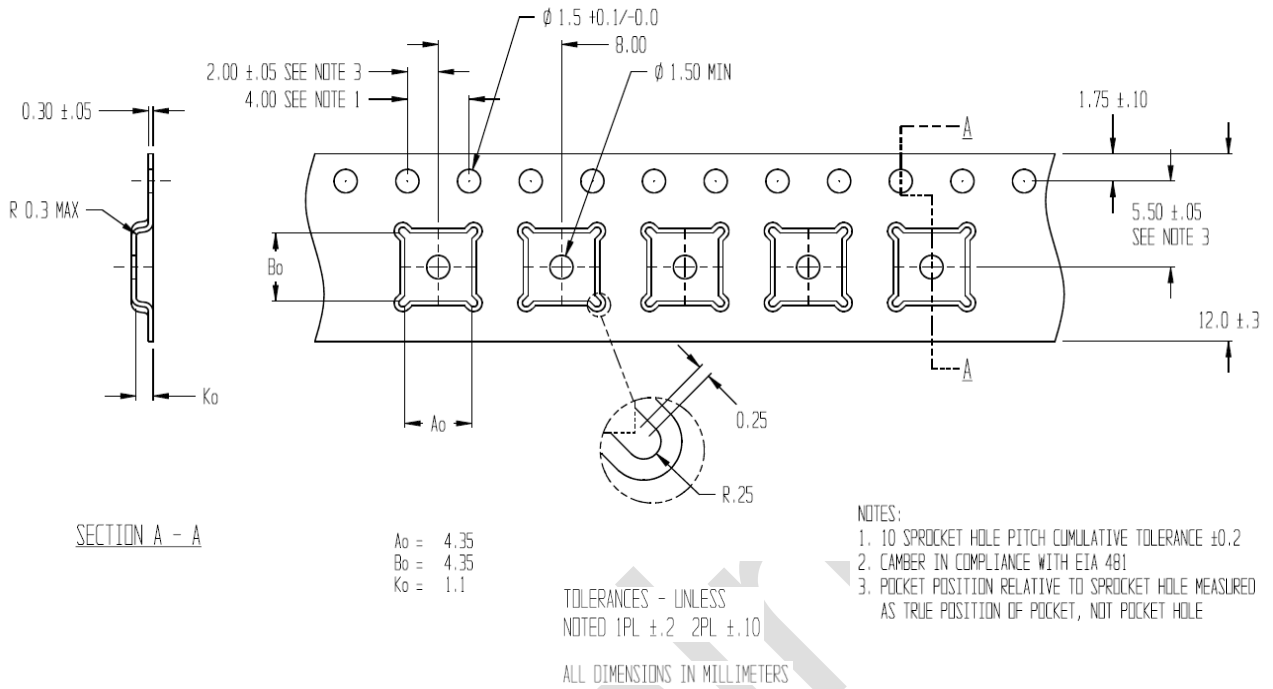

Tape Dimensions

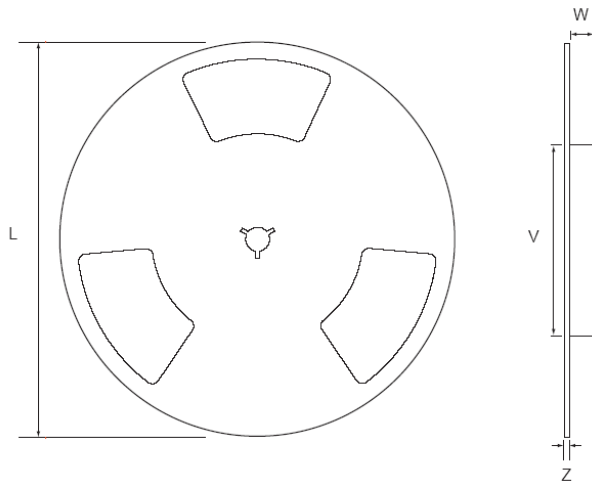

Reel Outline Drawing

Reel Dimensions and Package Size

PACKAGE SIZE	REEL (mm)			
	L	V	W	Z
4x4	330	100	13.2	2.2

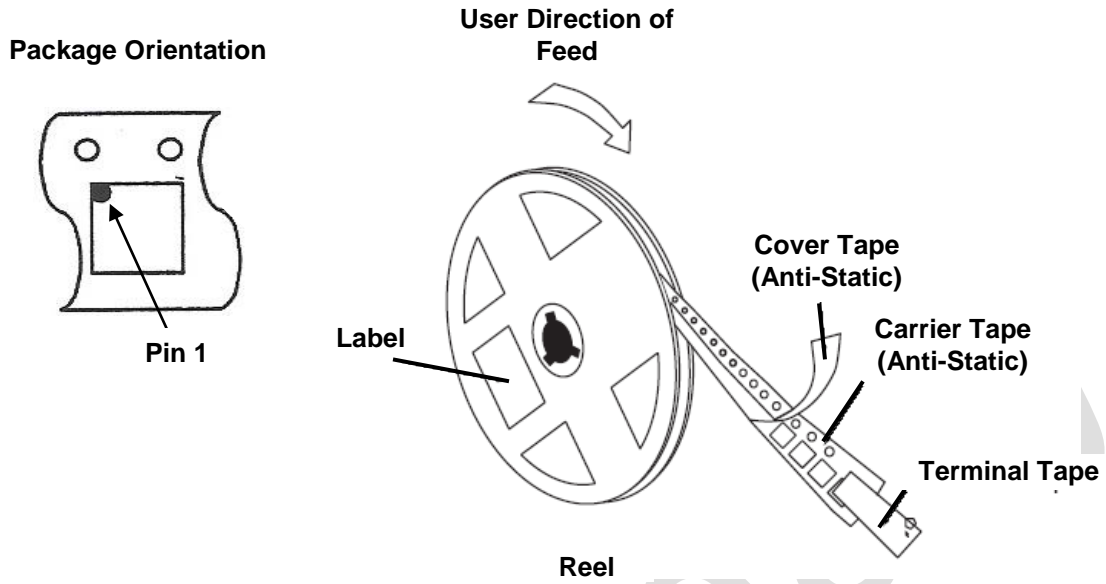

Tape and Reel Specification

Reel Specifications

Quantity Per Reel	5,000
Reels per Box	1
Boxes Per Carton (max)	3
Pieces per Carton (max)	15,000

8.9 Label

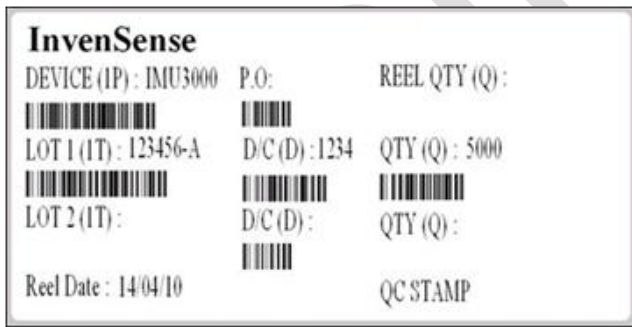

Location of Label

8.10 Packaging

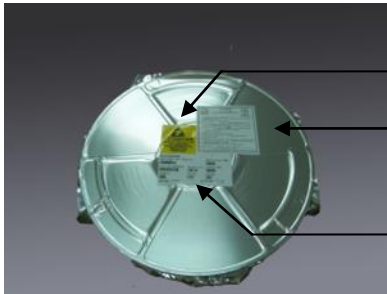

ESD Anti-static Label

Moisture-Sensitivity
Caution Label

Tape & Reel
Barcode Label

Moisture Barrier Bag
With Labels



Moisture-Sensitivity Caution Label



Reel in Box



Box with Tape & Reel Label

Preliminary



9 Reliability

9.1 Qualification Test Policy

Before InvenSense products are released for production, they complete a series of qualification tests. The Qualification Test Plan for the IMU-3000 followed the JEDEC JESD47G.01 Standard, "Stress-Test-Driven Qualification of Integrated Circuits." The individual tests are described below.

9.2 Qualification Test Plan

Accelerated Life Tests

TEST	Method/Condition	Lot Quantity	Sample / Lot	Acc / Reject Criteria
High Temperature Operating Life (HTOL/LFR)	JEDEC JESD22-A108C, Dynamic, 3.63V biased, $T_j > 125^\circ\text{C}$ [read-points 168, 500, 1000 hours]	3	77	(0/1)
Highly Accelerated Stress Test ⁽¹⁾ (HAST)	JEDEC JESD22-A118 Condition A, 130°C , 85%RH, 33.3 psia., unbiased, [read-point 96 hours]	3	77	(0/1)
High Temperature Storage Life (HTS)	JEDEC JESD22-A103C, Cond. A, 125°C , Non-Biased Bake [read-points 168, 500, 1000 hours]	3	77	(0/1)

Device Component Level Tests

TEST	Method/Condition	Lot Quantity	Sample / Lot	Acc / Reject Criteria
ESD-HBM	JEDEC JESD22-A114F, (1.5KV)	1	3	(0/1)
ESD-MM	JEDEC JESD22-A115-A, (200V)	1	3	(0/1)
Latch Up	JEDEC JESD78B Class II (2), 125°C ; Level B $\pm 60\text{mA}$	1	6	(0/1)
Mechanical Shock	JEDEC JESD22-B104C, Mil-Std-883H, method 2002.5, Cond. E, $10,000g$'s, 0.2ms, $\pm X, Y, Z$ – 6 directions, 5 times/direction	3	30	(0/1)
Vibration	JEDEC JESD22-B103B, Variable Frequency (random), Cond. B, 5-500Hz, X, Y, Z – 4 times/direction	3	5	(0/1)
Temperature Cycling (TC) ⁽¹⁾	JEDEC JESD22-A104D Condition N, [- 40°C to $+85^\circ\text{C}$], Soak Mode 2 [5'], 100 cycles	3	77	(0/1)

Board Level Tests

TEST	Method/Condition	Lot Quantity	Sample / Lot	Acc / Reject Criteria
Board Mechanical Shock	JEDEC JESD22-B104C, Mil-Std-883H, method 2002.5, Cond. E, $10000g$'s, 0.2ms, $+X, Y, Z$ – 6 directions, 5 times/direction	1	5	(0/1)
Board Temperature Cycling (TC) ⁽¹⁾	JEDEC JESD22-A104D Condition N, [- 40°C to $+85^\circ\text{C}$], Soak Mode 2 [5'], 100 cycles	1	40	(0/1)

(1) Tests are preceded by MSL3 Preconditioning in accordance with JEDEC JESD22-A113F



10 Environmental Compliance

The IMU-3000 is RoHS and Green compliant.

The IMU-3000 is in full environmental compliance as evidenced in report HS-IMU-3000, Materials Declaration Data Sheet.

Environmental Declaration Disclaimer:

InvenSense believes this environmental information to be correct but cannot guarantee accuracy or completeness. Conformity documents for the above component constitutes are on file. InvenSense subcontracts manufacturing and the information contained herein is based on data received from vendors and suppliers, which has not been validated by InvenSense.

Preliminary



IMU-3000 Product Specification

Document Number: PS-IMU-3000A-00
Revision: 1.3
Release Date: 05/25/2011

This information furnished by InvenSense is believed to be accurate and reliable. However, no responsibility is assumed by InvenSense for its use, or for any infringements of patents or other rights of third parties that may result from its use. Specifications are subject to change without notice. InvenSense reserves the right to make changes to this product, including its circuits and software, in order to improve its design and/or performance, without prior notice. InvenSense makes no warranties, neither expressed nor implied, regarding the information and specifications contained in this document. InvenSense assumes no responsibility for any claims or damages arising from information contained in this document, or from the use of products and services detailed therein. This includes, but is not limited to, claims or damages based on the infringement of patents, copyrights, mask work and/or other intellectual property rights.

Certain intellectual property owned by InvenSense and described in this document is patent protected. No license is granted by implication or otherwise under any patent or patent rights of InvenSense. This publication supersedes and replaces all information previously supplied. Trademarks that are registered trademarks are the property of their respective companies. InvenSense sensors should not be used or sold in the development, storage, production or utilization of any conventional or mass-destructive weapons or for any other weapons or life threatening applications, as well as in any other life critical applications such as medical equipment, transportation, aerospace and nuclear instruments, undersea equipment, power plant equipment, disaster prevention and crime prevention equipment.

InvenSense™, IMU™, IMU-3000™, Motion Processing Unit™, Digital Motion Processing™, DMP™, MotionApps™, MotionProcessing™ and MotionFusion™ are trademarks of InvenSense, Inc.

©2011 InvenSense, Inc. All rights reserved.

