



**InvenSense Inc.**

1197 Borregas Ave, Sunnyvale, CA 94089 U.S.A.  
Tel: +1 (408) 988-7339 Fax: +1 (408) 988-8104  
Website: [www.invensense.com](http://www.invensense.com)

Document Number: PS-ITG-3200A-00  
Revision: 1.6  
Release Date: 06/06/2011

**ITG-3200**  
**Product Specification**  
**Revision 1.6**

Preliminary



## CONTENTS

<b>1</b>	<b>DOCUMENT INFORMATION</b>	<b>3</b>
1.1	REVISION HISTORY	3
1.2	PURPOSE AND SCOPE	5
1.3	PRODUCT OVERVIEW	5
1.4	SOFTWARE SOLUTIONS	5
1.5	APPLICATIONS	6
<b>2</b>	<b>FEATURES</b>	<b>7</b>
<b>3</b>	<b>ELECTRICAL CHARACTERISTICS</b>	<b>8</b>
3.1	SENSOR SPECIFICATIONS	8
3.2	ELECTRICAL SPECIFICATIONS	9
3.3	ELECTRICAL SPECIFICATIONS, CONTINUED	10
3.4	ELECTRICAL SPECIFICATIONS, CONTINUED	11
3.5	I <sup>2</sup> C TIMING CHARACTERIZATION	12
3.6	ABSOLUTE MAXIMUM RATINGS	13
<b>4</b>	<b>APPLICATIONS INFORMATION</b>	<b>14</b>
4.1	PIN OUT AND SIGNAL DESCRIPTION	14
4.2	TYPICAL OPERATING CIRCUIT	15
4.3	BILL OF MATERIALS FOR EXTERNAL COMPONENTS	15
4.4	RECOMMENDED POWER-ON PROCEDURE	16
<b>5</b>	<b>FUNCTIONAL OVERVIEW</b>	<b>17</b>
5.1	BLOCK DIAGRAM	17
5.2	OVERVIEW	17
5.3	THREE-AXIS MEMS GYROSCOPE WITH 16-BIT ADCS AND SIGNAL CONDITIONING	17
5.4	I <sup>2</sup> C SERIAL COMMUNICATIONS INTERFACE	18
5.5	CLOCKING	18
5.6	SENSOR DATA REGISTERS	18
5.7	INTERRUPTS	18
5.8	DIGITAL-OUTPUT TEMPERATURE SENSOR	18
5.9	BIAS AND LDO	18
5.10	CHARGE PUMP	18
<b>6</b>	<b>DIGITAL INTERFACE</b>	<b>19</b>
6.1	I <sup>2</sup> C SERIAL INTERFACE	19
<b>7</b>	<b>ASSEMBLY</b>	<b>23</b>
7.1	ORIENTATION	23
7.2	PACKAGE DIMENSIONS	24
7.3	PCB DESIGN GUIDELINES:	25
7.4	ASSEMBLY PRECAUTIONS	26
7.5	PACKAGE MARKING SPECIFICATION	29
7.6	TAPE & REEL SPECIFICATION	30
7.7	LABEL	31
7.8	PACKAGING	32
<b>8</b>	<b>RELIABILITY</b>	<b>33</b>
8.1	QUALIFICATION TEST POLICY	33
8.2	QUALIFICATION TEST PLAN	33
<b>9</b>	<b>ENVIRONMENTAL COMPLIANCE</b>	<b>34</b>



## 1 Document Information

### 1.1 Revision History

Revision Date	Revision	Description
10/23/09	1.0	Initial Release
10/28/09	1.1	Edits for readability
02/12/2010	1.2	<ul style="list-style-type: none"><li>• Changed full-scale range and sensitivity scale factor (Sections 2, 3.1, 5.3, and 8.3)</li><li>• Changed sensitivity scale factor variation over temperature (Section 3.1)</li><li>• Changed total RMS noise spec (Section 3.1)</li><li>• Added range for temperature sensor (Section 3.1)</li><li>• Updated VDD Power-Supply Ramp Rate specification (Sections 3.2 and 4.4)</li><li>• Added VLOGIC Voltage Range condition (Section 3.2)</li><li>• Added VLOGIC Reference Voltage Ramp Rate specification (Sections 3.2 and 4.4)</li><li>• Updated Start-Up Time for Register Read/Write specification (Section 3.2)</li><li>• Updated Input logic levels for AD0 and CLKIN (Section 3.2)</li><li>• Updated Level <math>I_{OL}</math> specifications for the I<sup>2</sup>C interface (Section 3.3)</li><li>• Updated Frequency Variation Over Temperature specification for internal clock source (Section 3.4)</li><li>• Updated VLOGIC conditions for I<sup>2</sup>C Characterization (Section 3.5)</li><li>• Updated ESD specification (Section 3.6)</li><li>• Added termination requirements for CLKIN if unused (Section 4.1)</li><li>• Added recommended power-on procedure diagram (Section 4.4)</li><li>• Changed DLPF_CFG setting 7 to reserved (Section 8.3)</li><li>• Changed Reflow Specification description (Section 9.12)</li><li>• Removed errata specifications</li></ul>
03/05/2010	1.3	<ul style="list-style-type: none"><li>• Updated temperature sensor linearity spec (Section 3.1)</li><li>• Updated VDD Power-Supply Ramp Rate timing figure (Sections 3.2 and 4.4)</li><li>• Updated VLOGIC Reference Voltage timing figure (Section 4.4)</li><li>• Added default values to registers (all of Section 8)</li><li>• Updated FS_SEL description (Section 8.3)</li><li>• Updated package outline drawing and dimensions (Section 9.2)</li><li>• Updated Reliability (Section 10.1 and 10.2)</li><li>• Removed Environmental Compliance (Section 11)</li></ul>
03/30/2010	1.4	<ul style="list-style-type: none"><li>• Removed confidentiality mark</li></ul>
07/27/2010	1.5	<ul style="list-style-type: none"><li>• Changed Clock Frequency Initial Tolerance for CLKSEL=0, 25°C (Section 3.4)</li></ul>
06/06/2011	1.6	<ul style="list-style-type: none"><li>• Created separate document for Register Map and Register Descriptions</li><li>• Added section describing InvenSense software solutions (Section 1.4)</li><li>• Added specification for CLKOUT Digital Output (Section 3.2)</li><li>• Updated specifications for <math>C_I</math> (Sections 3.2-3.3)</li><li>• Updated specifications for <math>C_b</math> (Section 3.5)</li><li>• Updated Digital Input values and pins</li><li>• Clarified <math>T_{VLG-VDD}</math> value (Section 4.4)</li><li>• Documented inoperable I<sup>2</sup>C bus when VDD is low and interface pins are low impedance (Section 5.4)</li><li>• Modified Assembly Rules, packaging images and Moisture Sensitivity Level (MSL) label (Section 7)</li></ul>



**ITG-3200 Product Specification**

Document Number: PS-ITG-3200A-00  
Revision: 1.6  
Release Date: 06/06/2011

- Modified diagram for clarify (Section 7.3)
- Updated Reliability Testing Policy (Section 8)
- Added Environment Compliance Section (Section 9)

Preliminary



## 1.2 Purpose and Scope

This document is a preliminary product specification, providing a description, specifications, and design related information for the ITG-3200™. Electrical characteristics are based upon simulation results and limited characterization data of advanced samples only. Specifications are subject to change without notice. Final specifications will be updated based upon characterization of final silicon.

## 1.3 Product Overview

The ITG-3200 is the world's first single-chip, digital-output, 3-axis MEMS gyro IC optimized for gaming, 3D mice, and 3D remote control applications. The part features enhanced bias and sensitivity temperature stability, reducing the need for user calibration. Low frequency noise is lower than previous generation devices, simplifying application development and making for more-responsive remote controls.

The ITG-3200 features three 16-bit analog-to-digital converters (ADCs) for digitizing the gyro outputs, a user-selectable internal low-pass filter bandwidth, and a Fast-Mode I<sup>2</sup>C (400kHz) interface. Additional features include an embedded temperature sensor and a 2% accurate internal oscillator. This breakthrough in gyroscope technology provides a dramatic 67% package size reduction, delivers a 50% power reduction, and has inherent cost advantages compared to competing multi-chip gyro solutions.

By leveraging its patented and volume-proven Nasiri-Fabrication platform, which integrates MEMS wafers with companion CMOS electronics through wafer-level bonding, InvenSense has driven the ITG-3200 package size down to a revolutionary footprint of 4x4x0.9mm (QFN), while providing the highest performance, lowest noise, and the lowest cost semiconductor packaging required for handheld consumer electronic devices. The part features a robust 10,000g shock tolerance, as required by portable consumer equipment.

For power supply flexibility, the ITG-3200 has a separate VLOGIC reference pin, in addition to its analog supply pin, VDD, which sets the logic levels of its I<sup>2</sup>C interface. The VLOGIC voltage may be anywhere from 1.71V min to VDD max.

## 1.4 Software Solutions

This section describes the MotionApps™ software solutions included with the InvenSense MPU™ (MotionProcessing Unit™) and IMU (Inertial Measurement Unit) product families. Please note that the products within the IDG, IXZ, and ITG families do not include these software solutions.

The MotionApps Platform is a complete software solution that in combination with the InvenSense IMU and MPU MotionProcessor™ families delivers robust, well-calibrated 6-axis and/or 9-axis sensor fusion data using its field proven and proprietary MotionFusion™ engine. Solution packages are available for smartphones and tablets as well as for embedded microcontroller-based devices.

The MotionApps Platform provides a turn-key solution for developers and accelerates time-to-market. It consists of complex 6/9-axis sensor fusion algorithms, robust multi-sensor calibration, a proven software architecture for Android and other leading operating systems, and a flexible power management scheme.

The MotionApps Platform is integrated within the middleware of the target OS (the sensor framework), and also provides a kernel device driver to interface with the physical device. This directly benefits application developers by providing a cohesive set of APIs and a well-defined sensor data path in the user-space.



The table below describes the MotionApps software solutions included with the InvenSense MPU and IMU product families.

**InvenSense MotionProcessor Devices and Included MotionApps Software**

Feature	Included Software				Notes
	MotionApps	Embedded MotionApps	MotionApps Lite	Embedded MotionApps Lite	
Part Number	MPU-3050™ MPU-6050™		IMU-3000™		
Processor Type	Mobile Application Processor	8/16/32-bit Microcontroller	Mobile Application Processor	8/16/32-bit Microcontroller	
Applications	Smartphones, tablets	TV remotes, health/fitness, toys, other embedded	Smartphones, tablets	TV remotes, health/fitness, toys, other embedded	
6-Axis MotionFusion	Yes		Yes		< 2% Application Processor load using on-chip Digital Motion Processor (DMP). Reduces processing requirements for embedded applications
9-Axis MotionFusion	Yes		No		
Gyro Bias Calibration	Yes		Yes		No-Motion calibration and temperature calibration
3 <sup>rd</sup> Party Compass Cal API	Yes		No		Integrates 3 <sup>rd</sup> party compass libraries
Gyro-Assisted Compass Calibration (Fast Heading)	Yes		No		Quick compass calibration using gyroscope
Magnetic Anomaly Rejection (Improved Heading)	Yes		No		Uses gyro heading data when magnetic anomaly is detected

The table below lists recommended documentation for the MotionApps software solutions.

**Software Documentation**

Platform	MotionApps and MotionApps Lite	Embedded MotionApps and Embedded MotionApps Lite
Software Documentation	<ul style="list-style-type: none"> <li>Installation Guide for Linux and Android MotionApps Platform, v1.9 or later</li> <li>MPL Functional Specifications</li> </ul>	<ul style="list-style-type: none"> <li>Embedded MotionApps Platform User Guide, v3.0 or later</li> <li>Embedded MPL Functional Specifications</li> </ul>

For more information about the InvenSense MotionApps Platform, please visit the Developer's Corner or consult your local InvenSense Sales Representative.

**1.5 Applications**

- Motion-enabled game controllers
- Motion-based portable gaming
- Motion-based 3D mice and 3D remote controls
- "No Touch" UI
- Health and sports monitoring

## 2 Features

The ITG-3200 triple-axis MEMS gyroscope includes a wide range of features:

- Digital-output X-, Y-, and Z-Axis angular rate sensors (gyros) on one integrated circuit with a sensitivity of 14.375 LSBs per °/sec and a full-scale range of  $\pm 2000^\circ/\text{sec}$
- Three integrated 16-bit ADCs provide simultaneous sampling of gyros while requiring no external multiplexer
- Enhanced bias and sensitivity temperature stability reduces the need for user calibration
- Low frequency noise lower than previous generation devices, simplifying application development and making for more-responsive motion processing
- Digitally-programmable low-pass filter
- Low 6.5mA operating current consumption for long battery life
- Wide VDD supply voltage range of 2.1V to 3.6V
- Flexible VLOGIC reference voltage allows for I<sup>2</sup>C interface voltages from 1.71V to VDD
- Standby current: 5 $\mu$ A
- Smallest and thinnest package for portable devices (4x4x0.9mm QFN)
- No high pass filter needed
- Turn on time: 50ms
- Digital-output temperature sensor
- Factory calibrated scale factor
- 10,000 g shock tolerant
- Fast Mode I<sup>2</sup>C (400kHz) serial interface
- On-chip timing generator clock frequency is accurate to  $\pm 2\%$  over full temperature range
- Optional external clock inputs of 32.768kHz or 19.2MHz to synchronize with system clock
- MEMS structure hermetically sealed and bonded at wafer level
- RoHS and Green compliant



### 3 Electrical Characteristics

#### 3.1 Sensor Specifications

Typical Operating Circuit of Section 4.2, VDD = 2.5V, VLOGIC = 1.71V to VDD, T<sub>A</sub>=25°C.

Parameter	Conditions	Min	Typical	Max	Unit	Note
<b>GYRO SENSITIVITY</b>						
Full-Scale Range	FS_SEL=3		±2000		°/s	4
Gyro ADC Word Length			16		Bits	3
Sensitivity Scale Factor	FS_SEL=3		14.375		LSB/(°/s)	3
Sensitivity Scale Factor Tolerance	25°C	-6		+6	%	1
Sensitivity Scale Factor Variation Over Temperature			±10		%	2
Nonlinearity	Best fit straight line; 25°C		0.2		%	6
Cross-Axis Sensitivity			2		%	6
<b>GYRO ZERO-RATE OUTPUT (ZRO)</b>						
Initial ZRO Tolerance			±40		°/s	1
ZRO Variation Over Temperature	-40°C to +85°C		±40		°/s	2
Power-Supply Sensitivity (1-10Hz)	Sine wave, 100mVpp; VDD=2.2V		0.2		°/s	5
Power-Supply Sensitivity (10 - 250Hz)	Sine wave, 100mVpp; VDD=2.2V		0.2		°/s	5
Power-Supply Sensitivity (250Hz - 100kHz)	Sine wave, 100mVpp; VDD=2.2V		4		°/s	5
Linear Acceleration Sensitivity	Static		0.1		°/s/g	6
<b>GYRO NOISE PERFORMANCE</b>						
Total RMS noise	FS_SEL=3 100Hz LPF (DLPFCFG=2)		0.38		°/s-rms	1
Rate Noise Spectral Density	At 10Hz		0.03		°/s/√Hz	2
<b>GYRO MECHANICAL FREQUENCIES</b>						
X-Axis		30	33	36	kHz	1
Y-Axis		27	30	33	kHz	1
Z-Axis		24	27	30	kHz	1
Frequency Separation	Between any two axes	1.7			kHz	1
<b>GYRO START-UP TIME</b>						
ZRO Settling	DLPFCFG=0 to ±1°/s of Final		50		ms	6
<b>TEMPERATURE SENSOR</b>						
Range			-30 to +85		°C	2
Sensitivity			280		LSB/°C	2
Temperature Offset	35°C		-13,200		LSB	1
Initial Accuracy	35°C		TBD		°C	
Linearity	Best fit straight line (-30°C to +85°C)		±1		°C	2, 5
<b>TEMPERATURE RANGE</b>						
Specified Temperature Range		-40		85	°C	

**Notes:**

1. Tested in production
2. Based on characterization of 30 pieces over temperature on evaluation board or in socket
3. Based on design, through modeling and simulation across PVT
4. Typical. Randomly selected part measured at room temperature on evaluation board or in socket
5. Based on characterization of 5 pieces over temperature
6. Tested on 5 parts at room temperature



### 3.2 Electrical Specifications

Typical Operating Circuit of Section 4.2, VDD = 2.5V, VLOGIC = 1.71V to VDD, T<sub>A</sub>=25°C.

Parameters	Conditions	Min	Typical	Max	Units	Notes
<b>VDD POWER SUPPLY</b>						
Operating Voltage Range	Monotonic ramp. Ramp rate is 10% to 90% of the final value (see Figure in Section 4.4)	2.1		3.6	V	2
Power-Supply Ramp Rate		0		5	ms	2
Normal Operating Current			6.5		mA	1
Sleep Mode Current			5		μA	5
<b>VLOGIC REFERENCE VOLTAGE</b>						
Voltage Range	VLOGIC must be ≤VDD at all times	1.71		VDD	V	
VLOGIC Ramp Rate	Monotonic ramp. Ramp rate is 10% to 90% of the final value (see Figure in Section 4.4)			1	ms	6
Normal Operating Current			100		μA	
<b>START-UP TIME FOR REGISTER READ/WRITE</b>						
			20		ms	5
<b>I<sup>2</sup>C ADDRESS</b>						
	AD0 = 0		1101000			6
	AD0 = 1		1101001			6
<b>DIGITAL INPUTS (SDA, SCL, AD0, CLKIN)</b>						
V <sub>IH</sub> , High Level Input Voltage		0.7*VLOGIC			V	5
V <sub>IL</sub> , Low Level Input Voltage				0.3*VLOGIC	V	5
C <sub>i</sub> , Input Capacitance			< 5		pF	7
<b>DIGITAL OUTPUT (INT)</b>						
V <sub>OH</sub> , High Level Output Voltage	OPEN=0, Rload=1MΩ	0.9*VLOGIC			V	2
V <sub>OL</sub> , Low Level Output Voltage	OPEN=0, Rload=1MΩ			0.1*VLOGIC	V	2
V <sub>OL,INT1</sub> , INT Low-Level Output Voltage	OPEN=1, 0.3mA sink current			0.1	V	2
Output Leakage Current	OPEN=1		100		nA	4
t <sub>INT</sub> , INT Pulse Width	LATCH_INT_EN=0		50		μs	4
<b>DIGITAL OUTPUT (CLKOUT)</b>						
V <sub>OH</sub> , High Level Output Voltage	RLOAD=1MΩ	0.9*VDD			V	2
V <sub>OL1</sub> , LOW-Level Output Voltage	RLOAD=1MΩ			0.1*VDD	V	2

**Notes:**

1. Tested in production
2. Based on characterization of 30 pieces over temperature on evaluation board or in socket
4. Typical. Randomly selected part measured at room temperature on evaluation board or in socket
5. Based on characterization of 5 pieces over temperature
6. Guaranteed by design



### 3.3 Electrical Specifications, continued

Typical Operating Circuit of Section 4.2, VDD = 2.5V, VLOGIC = 1.71V to VDD, T<sub>A</sub>=25°C.

Parameters	Conditions	Typical	Units	Notes
<b>I<sup>2</sup>C I/O (SCL, SDA)</b>				
V <sub>IL</sub> , LOW-Level Input Voltage		-0.5 to 0.3*VLOGIC	V	2
V <sub>IH</sub> , HIGH-Level Input Voltage		0.7*VLOGIC to VLOGIC + 0.5V	V	2
V <sub>hys</sub> , Hysteresis		0.1*VLOGIC	V	2
V <sub>OL1</sub> , LOW-Level Output Voltage	3mA sink current	0 to 0.4	V	2
I <sub>OL</sub> , LOW-Level Output Current	V <sub>OL</sub> = 0.4V	3	mA	2
	V <sub>OL</sub> = 0.6V	6	mA	2
Output Leakage Current		100	nA	4
t <sub>of</sub> , Output Fall Time from V <sub>IHmax</sub> to V <sub>ILmax</sub>	C <sub>b</sub> bus cap. in pF	20+0.1C <sub>b</sub> to 250	ns	2
C <sub>I</sub> , Capacitance for Each I/O pin		< 10	pF	5

**Notes:**

2. Based on characterization of 5 pieces over temperature.
4. Typical. Randomly selected part measured at room temperature on evaluation board or in socket
5. Guaranteed by design



**3.4 Electrical Specifications, continued**

Typical Operating Circuit of Section 4.2, VDD = 2.5V, VLOGIC = 1.71V to VDD, T<sub>A</sub>=25°C.

Parameters	Conditions	Min	Typical	Max	Units	Notes
<b>INTERNAL CLOCK SOURCE</b>						
Sample Rate, Fast	CLKSEL=0, 1, 2, or 3 DLPFCFG=0 SAMPLERATEDIV = 0		8		kHz	4
Sample Rate, Slow	DLPFCFG=1,2,3,4,5, or 6 SAMPLERATEDIV = 0		1		kHz	4
Clock Frequency Initial Tolerance	CLKSEL=0, 25°C	-5		+5	%	1
	CLKSEL=1,2,3; 25°C	-1		+1	%	1
Frequency Variation over Temperature	CLKSEL=0		-15 to +10		%	2
	CLKSEL=1,2,3		+/-1		%	2
PLL Settling Time	CLKSEL=1,2,3		1		ms	3
<b>EXTERNAL 32.768kHz CLOCK</b>						
External Clock Frequency	CLKSEL=4		32.768		kHz	3
External Clock Jitter	Cycle-to-cycle rms		1 to 2		µs	3
Sample Rate, Fast	DLPFCFG=0 SAMPLERATEDIV = 0		8.192		kHz	3
Sample Rate, Slow	DLPFCFG=1,2,3,4,5, or 6 SAMPLERATEDIV = 0		1.024		kHz	3
PLL Settling Time			1		ms	3
<b>EXTERNAL 19.2MHz CLOCK</b>						
External Clock Frequency	CLKSEL=5		19.2		MHz	3
Sample Rate, Fast	DLPFCFG=0 SAMPLERATEDIV = 0		8		kHz	3
Sample Rate, Slow	DLPFCFG=1,2,3,4,5, or 6 SAMPLERATEDIV = 0		1		kHz	3
PLL Settling Time			1		ms	3
<b>Charge Pump Clock Frequency</b>						
Frequency	1 <sup>st</sup> Stage, 25°C		8.5		MHz	5
	2 <sup>nd</sup> Stage, 25°C		68		MHz	5
	Over temperature		+/-15		%	5

**Notes:**

1. Tested in production
2. Based on characterization of 30 pieces over temperature on evaluation board or in socket
3. Based on design, through modeling and simulation across PVT
4. Typical. Randomly selected part measured at room temperature on evaluation board or in socket
5. Based on characterization of 5 pieces over temperature.

### 3.5 I<sup>2</sup>C Timing Characterization

Typical Operating Circuit of Section 4.2, VDD = 2.5V, VLOGIC = 1.8V±5%, 2.5V±5%, 3.0V±5%, or 3.3V±5%, T<sub>A</sub>=25°C.

Parameters	Conditions	Min	Typical	Max	Units	Notes
<b>I<sup>2</sup>C TIMING</b>						
<b>I<sup>2</sup>C FAST-MODE</b>						
f <sub>SCL</sub> , SCL Clock Frequency		0		400	kHz	1
t <sub>HD,STA</sub> , (Repeated) START Condition Hold Time		0.6			us	1
t <sub>LOW</sub> , SCL Low Period		1.3			us	1
t <sub>HIGH</sub> , SCL High Period		0.6			us	1
t <sub>SU,STA</sub> , Repeated START Condition Setup Time		0.6			us	1
t <sub>HD,DAT</sub> , SDA Data Hold Time		0			us	1
t <sub>SU,DAT</sub> , SDA Data Setup Time		100			ns	1
t <sub>r</sub> , SDA and SCL Rise Time	C <sub>b</sub> bus cap. from 10 to 400pF	20+0.1C <sub>b</sub>		300	ns	1
t <sub>f</sub> , SDA and SCL Fall Time	C <sub>b</sub> bus cap. from 10 to 400pF	20+0.1C <sub>b</sub>		300	ns	1
t <sub>SU,STO</sub> , STOP Condition Setup Time		0.6			us	1
t <sub>BUF</sub> , Bus Free Time Between STOP and START Condition		1.3			us	1
C <sub>b</sub> , Capacitive Load for each Bus Line			< 400		pF	2
t <sub>VD,DAT</sub> , Data Valid Time				0.9	us	1
t <sub>VD,ACK</sub> , Data Valid Acknowledge Time				0.9	us	1

#### Notes:

1. Based on characterization of 5 pieces over temperature on evaluation board or in socket
2. Guaranteed by design

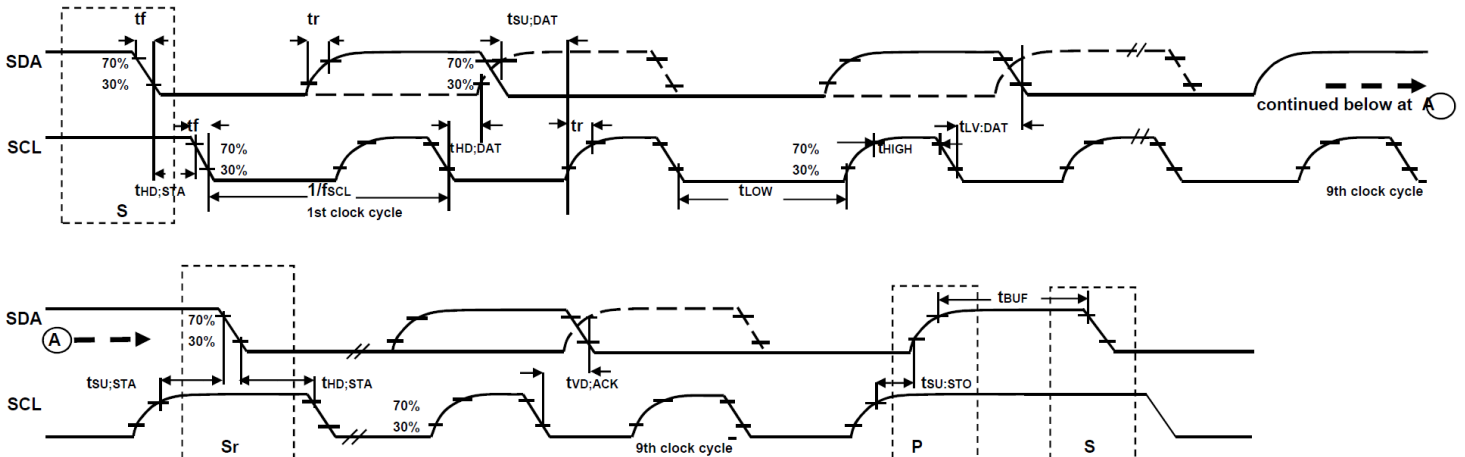

**I<sup>2</sup>C Bus Timing Diagram**

### 3.6 Absolute Maximum Ratings

Stresses above those listed as “Absolute Maximum Ratings” may cause permanent damage to the device. These are stress ratings only and functional operation of the device at these conditions is not implied. Exposure to the absolute maximum ratings conditions for extended periods may affect device reliability.

#### Absolute Maximum Ratings

Parameter	Rating
Supply Voltage, VDD	-0.5V to +6V
VLOGIC Input Voltage Level	-0.5V to VDD + 0.5V
REGOUT	-0.5V to 2V
Input Voltage Level (CLKIN, AD0)	-0.5V to VDD + 0.5V
SCL, SDA, INT	-0.5V to VLOGIC + 0.5V
CPOUT (2.1V ≤ VDD ≤ 3.6V )	-0.5V to 30V
Acceleration (Any Axis, unpowered)	10,000g for 0.3ms
Operating Temperature Range	-40°C to +105°C
Storage Temperature Range	-40°C to +125°C
Electrostatic Discharge (ESD) Protection	1.5kV (HBM); 200V (MM)

## 4 Applications Information

### 4.1 Pin Out and Signal Description

Number	Pin	Pin Description
1	CLKIN	Optional external reference clock input. Connect to GND if unused.
8	VLOGIC	Digital IO supply voltage. VLOGIC must be $\leq$ VDD at all times.
9	AD0	I <sup>2</sup> C Slave Address LSB
10	REGOUT	Regulator filter capacitor connection
12	INT	Interrupt digital output (totem pole or open-drain)
13	VDD	Power supply voltage
18	GND	Power supply ground
11	RESV-G	Reserved - Connect to ground.
6, 7, 19, 21, 22	RESV	Reserved. Do not connect.
20	CPOUT	Charge pump capacitor connection
23	SCL	I <sup>2</sup> C serial clock
24	SDA	I <sup>2</sup> C serial data
2, 3, 4, 5, 14, 15, 16, 17	NC	Not internally connected. May be used for PCB trace routing.

**Top View**

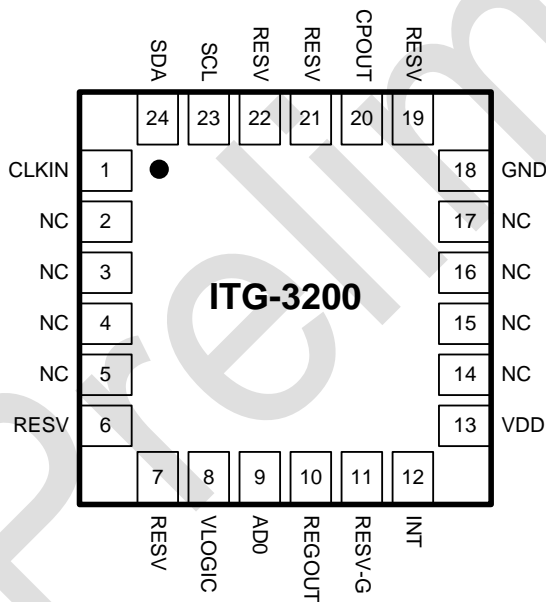

**QFN Package**  
 24-pin, 4mm x 4mm x 0.9mm

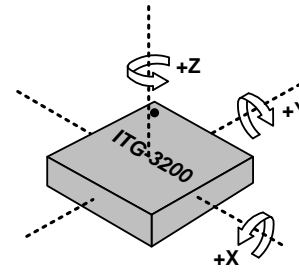

**Orientation of Axes of Sensitivity**  
**and Polarity of Rotation**

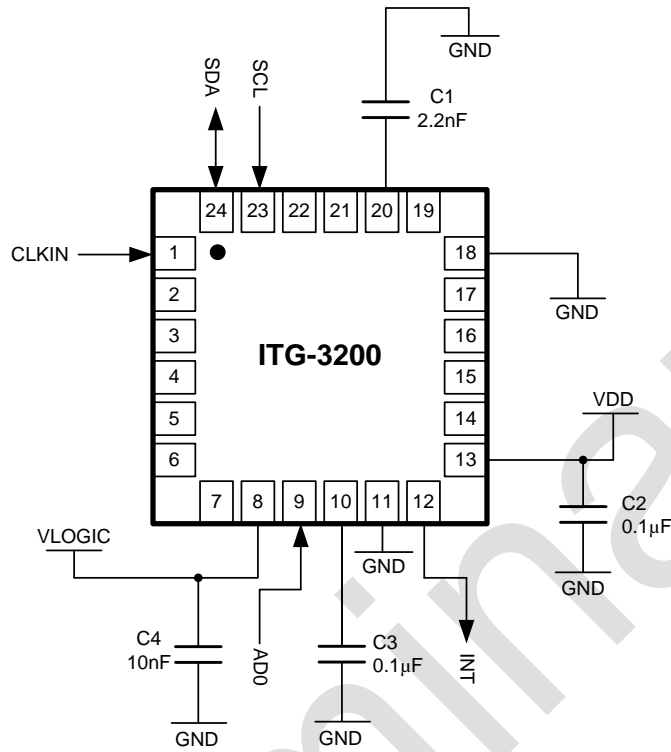
**4.2 Typical Operating Circuit**

**Typical Operating Circuit**
**4.3 Bill of Materials for External Components**

Component	Label	Specification	Quantity
Charge Pump Capacitor	C1	Ceramic, X7R, 2.2nF ±10%, 50V	1
VDD Bypass Capacitor	C2	Ceramic, X7R, 0.1µF ±10%, 4V	1
Regulator Filter Capacitor	C3	Ceramic, X7R, 0.1µF ±10%, 2V	1
VLOGIC Bypass Capacitor	C4	Ceramic, X7R, 10nF ±10%, 4V	1

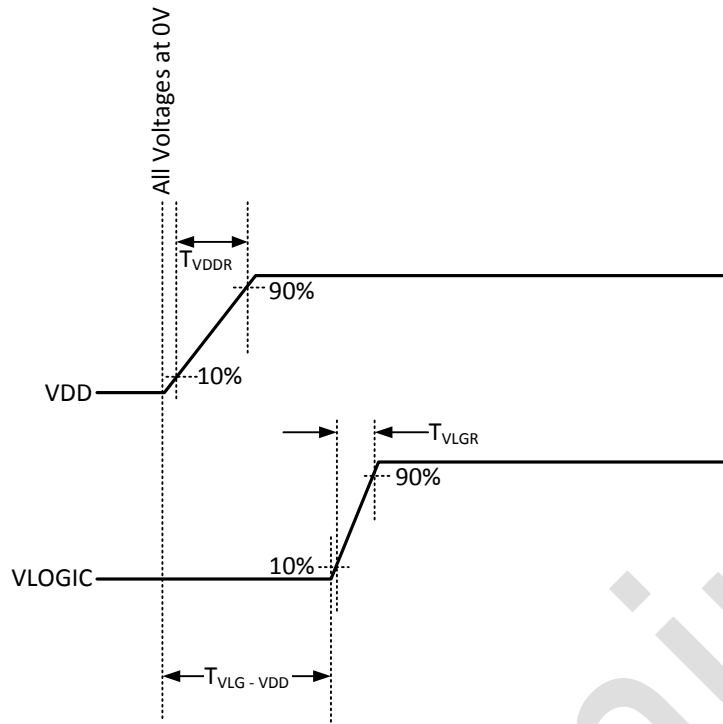
#### 4.4 Recommended Power-On Procedure



#### Power-Up Sequencing

1.  $T_{VDDR}$  is VDD rise time: Time for VDD to rise from 10% to 90% of its final value
2.  $T_{VDDR}$  is  $\leq 5\text{msec}$
3.  $T_{VLGR}$  is VLOGIC rise time: Time for VLOGIC to rise from 10% to 90% of its final value
4.  $T_{VLGR}$  is  $\leq 1\text{msec}$
5.  $T_{VLG-VDD}$  is the delay from the start of VDD ramp to the start of VLOGIC rise
6.  $T_{VLG-VDD}$  is  $\geq 0$ ; VLOGIC amplitude must always be  $\leq$  VDD amplitude
7. VDD and VLOGIC must be monotonic ramps

Preliminary

## 5 Functional Overview

### 5.1 Block Diagram

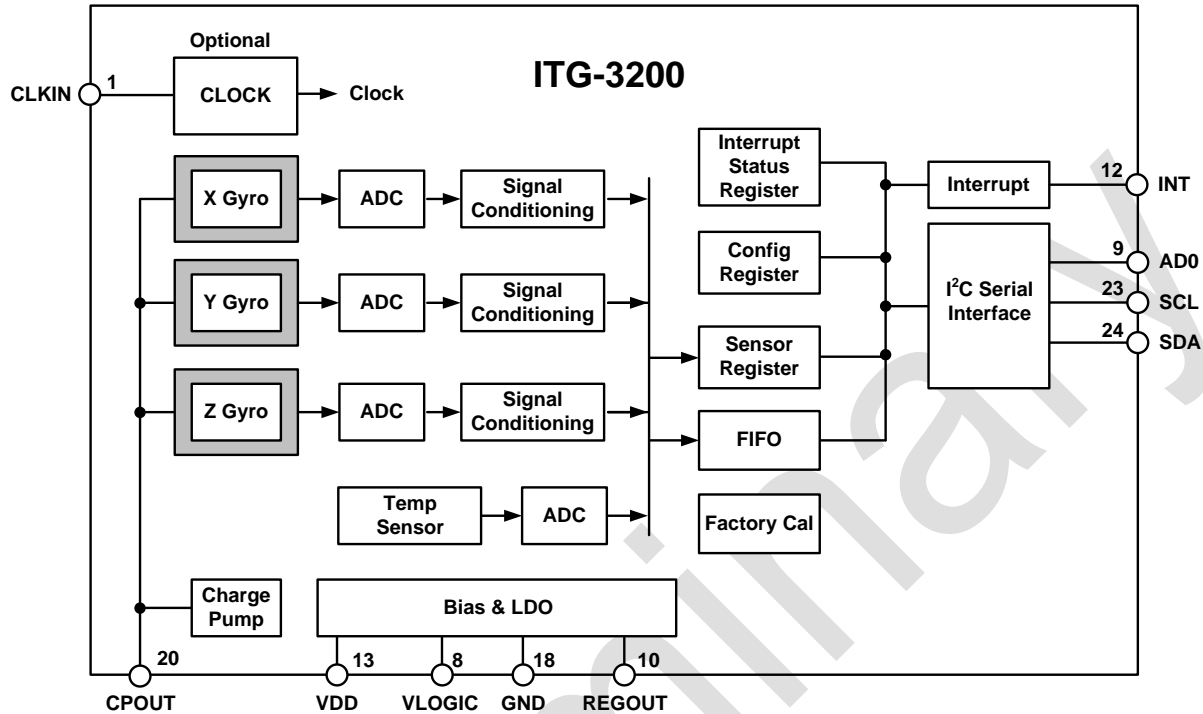

### 5.2 Overview

The ITG-3200 consists of the following key blocks and functions:

- Three-axis MEMS rate gyroscope sensors with individual 16-bit ADCs and signal conditioning
- I<sup>2</sup>C serial communications interface
- Clocking
- Sensor Data Registers
- Interrupts
- Digital-Output Temperature Sensor
- Bias and LDO
- Charge Pump

### 5.3 Three-Axis MEMS Gyroscope with 16-bit ADCs and Signal Conditioning

The ITG-3200 consists of three independent vibratory MEMS gyroscopes, which detect rotational rate about the X (roll), Y (pitch), and Z (yaw) axes. When the gyros are rotated about any of the sense axes, the Coriolis Effect causes a deflection that is detected by a capacitive pickoff. The resulting signal is amplified, demodulated, and filtered to produce a voltage that is proportional to the angular rate. This voltage is digitized using individual on-chip 16-bit Analog-to-Digital Converters (ADCs) to sample each axis.

The full-scale range of the gyro sensors is preset to  $\pm 2000$  degrees per second ( $^{\circ}/s$ ). The ADC output rate is programmable up to a maximum of 8,000 samples per second down to 3.9 samples per second, and user-selectable low-pass filters enable a wide range of cut-off frequencies.

#### 5.4 I<sup>2</sup>C Serial Communications Interface

The ITG-3200 communicates to a system processor using the I<sup>2</sup>C serial interface, and the device always acts as a slave when communicating to the system processor. **The logic level for communications to the master is set by the voltage on the VLOGIC pin.** The LSB of the of the I<sup>2</sup>C slave address is set by pin 9 (AD0).

Note: When VDD is low, the I<sup>2</sup>C interface pins become low impedance and thus can load the serial bus. This is a concern if other devices are active on the bus during this time.

#### 5.5 Clocking

The ITG-3200 has a flexible clocking scheme, allowing for a variety of internal or external clock sources for the internal synchronous circuitry. This synchronous circuitry includes the signal conditioning, ADCs, and various control circuits and registers. An on-chip PLL provides flexibility in the allowable inputs for generating this clock.

Allowable internal sources for generating the internal clock are:

- An internal relaxation oscillator (less accurate)
- Any of the X, Y, or Z gyros' MEMS oscillators (with an accuracy of  $\pm 2\%$  over temperature)

Allowable external clocking sources are:

- 32.768kHz square wave
- 19.2MHz square wave

Which source to select for generating the internal synchronous clock depends on the availability of external sources and the requirements for clock accuracy. There are also start-up conditions to consider. When the ITG-3200 first starts up, the device operates off of its internal clock until programmed to operate from another source. This allows the user, for example, to wait for the MEMS oscillators to stabilize before they are selected as the clock source.

#### 5.6 Sensor Data Registers

The sensor data registers contain the latest gyro and temperature data. They are read-only registers, and are accessed via the Serial Interface. Data from these registers may be read at any time, however, the interrupt function may be used to determine when new data is available.

#### 5.7 Interrupts

Interrupt functionality is configured via the Interrupt Configuration register. Items that are configurable include the INT pin configuration, the interrupt latching and clearing method, and triggers for the interrupt. Items that can trigger an interrupt are (1) Clock generator locked to new reference oscillator (used when switching clock sources); and (2) new data is available to be read from the Data registers. The interrupt status can be read from the Interrupt Status register.

#### 5.8 Digital-Output Temperature Sensor

An on-chip temperature sensor and ADC are used to measure the ITG-3200 die temperature. The readings from the ADC can be read from the Sensor Data registers.

#### 5.9 Bias and LDO

The bias and LDO sections take in an unregulated VDD supply from 2.1V to 3.6V and generate the internal supply and the references voltages and currents required by the ITG-3200. The LDO output is bypassed by a capacitor at REGOUT. Additionally, the part has a VLOGIC reference voltage which sets the logic levels for its I<sup>2</sup>C interface.

#### 5.10 Charge Pump

An on-board charge pump generates the high voltage (25V) required to drive the MEMS oscillators. Its output is bypassed by a capacitor at CPOUT.

## 6 Digital Interface

### 6.1 I<sup>2</sup>C Serial Interface

The internal registers and memory of the ITG-3200 can be accessed using I<sup>2</sup>C at up to 400kHz.

#### Serial Interface

Pin Number	Pin Name	Pin Description
8	VLOGIC	Digital IO supply voltage. VLOGIC must be $\leq$ VDD at all times.
9	AD0	I <sup>2</sup> C Slave Address LSB
23	SCL	I <sup>2</sup> C serial clock
24	SDA	I <sup>2</sup> C serial data

#### 6.1.1 I<sup>2</sup>C Interface

I<sup>2</sup>C is a two wire interface comprised of the signals serial data (SDA) and serial clock (SCL). In general, the lines are open-drain and bi-directional. In a generalized I<sup>2</sup>C interface implementation, attached devices can be a master or a slave. The master device puts the slave address on the bus, and the slave device with the matching address acknowledges the master.

The ITG-3200 always operates as a slave device when communicating to the system processor, which thus acts as the master. SDA and SCL lines typically need pull-up resistors to VDD. The maximum bus speed is 400kHz.

The slave address of the ITG-3200 devices is b110100X which is 7 bits long. The LSB bit of the 7 bit address is determined by the logic level on pin 9. This allows two ITG-3200 devices to be connected to the same I<sup>2</sup>C bus. When used in this configuration, the address of the one of the devices should be b1101000 (pin 9 is logic low) and the address of the other should be b1101001 (pin 9 is logic high). The I<sup>2</sup>C address is stored in register 0 (WHO\_AM\_I register).

#### I<sup>2</sup>C Communications Protocol

##### START (S) and STOP (P) Conditions

Communication on the I<sup>2</sup>C bus starts when the master puts the START condition (S) on the bus, which is defined as a HIGH-to-LOW transition of the SDA line while SCL line is HIGH (see figure below). The bus is considered to be busy until the master puts a STOP condition (P) on the bus, which is defined as a LOW to HIGH transition on the SDA line while SCL is HIGH (see figure below).

Additionally, the bus remains busy if a repeated START (Sr) is generated instead of a STOP condition.

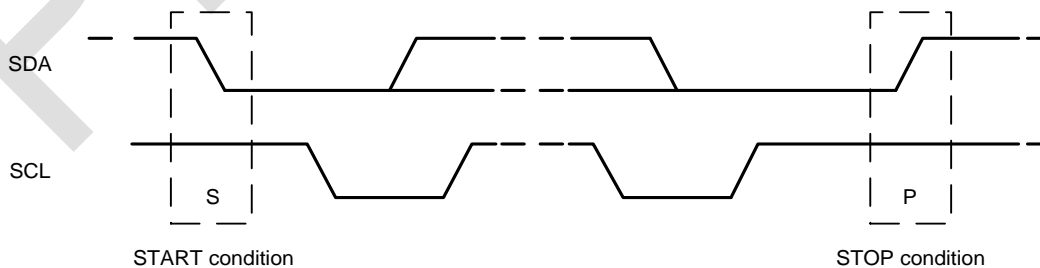

**START and STOP Conditions**

Data Format / Acknowledge

I<sup>2</sup>C data bytes are defined to be 8 bits long. There is no restriction to the number of bytes transmitted per data transfer. Each byte transferred must be followed by an acknowledge (ACK) signal. The clock for the acknowledge signal is generated by the master, while the receiver generates the actual acknowledge signal by pulling down SDA and holding it low during the HIGH portion of the acknowledge clock pulse.

If a slave is busy and cannot transmit or receive another byte of data until some other task has been performed, it can hold SCL LOW, thus forcing the master into a wait state. Normal data transfer resumes when the slave is ready, and releases the clock line (see figure below).

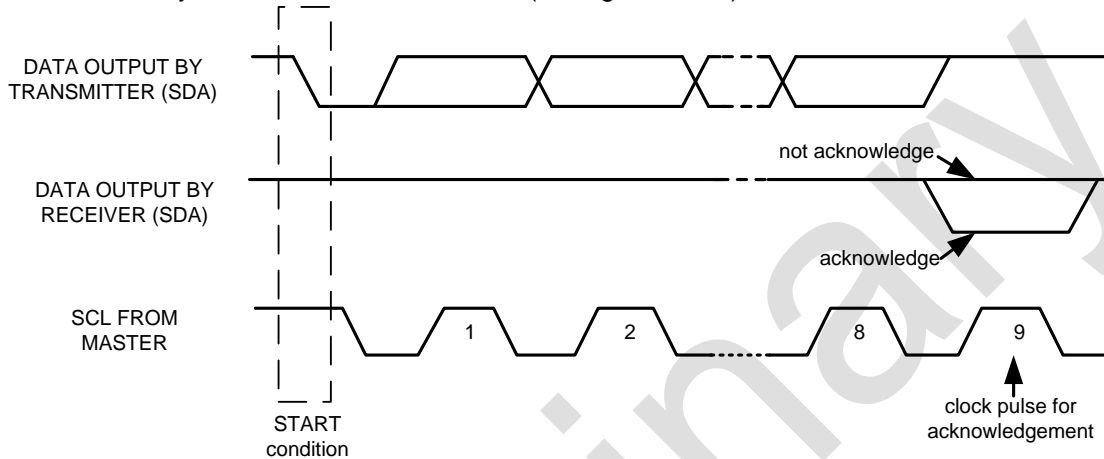

**Acknowledge on the I<sup>2</sup>C Bus**

Communications

After beginning communications with the START condition (S), the master sends a 7-bit slave address followed by an 8<sup>th</sup> bit, the read/write bit. The read/write bit indicates whether the master is receiving data from or is writing to the slave device. Then, the master releases the SDA line and waits for the acknowledge signal (ACK) from the slave device. Each byte transferred must be followed by an acknowledge bit. To acknowledge, the slave device pulls the SDA line LOW and keeps it LOW for the high period of the SCL line. Data transmission is always terminated by the master with a STOP condition (P), thus freeing the communications line. However, the master can generate a repeated START condition (Sr), and address another slave without first generating a STOP condition (P). A LOW to HIGH transition on the SDA line while SCL is HIGH defines the stop condition. All SDA changes should take place when SCL is low, with the exception of start and stop conditions.

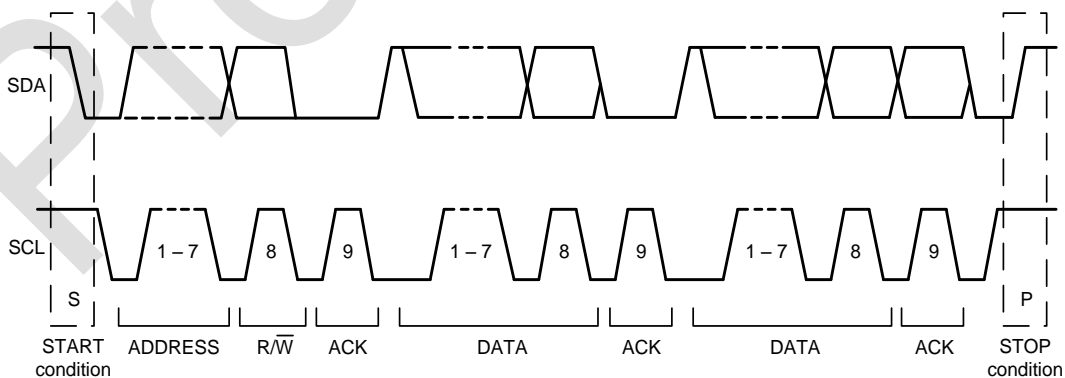

**Complete I<sup>2</sup>C Data Transfer**



To write the internal ITG-3200 device registers, the master transmits the start condition (S), followed by the I<sup>2</sup>C address and the write bit (0). At the 9<sup>th</sup> clock cycle (when the clock is high), the ITG-3200 device acknowledges the transfer. Then the master puts the register address (RA) on the bus. After the ITG-3200 acknowledges the reception of the register address, the master puts the register data onto the bus. This is followed by the ACK signal, and data transfer may be concluded by the stop condition (P). To write multiple bytes after the last ACK signal, the master can continue outputting data rather than transmitting a stop signal. In this case, the ITG-3200 device automatically increments the register address and loads the data to the appropriate register. The following figures show single and two-byte write sequences.

**Single-Byte Write Sequence**

Master	S	AD+W		RA		DATA		P
Slave			ACK		ACK		ACK	

**Burst Write Sequence**

Master	S	AD+W		RA		DATA		DATA		P
Slave			ACK		ACK		ACK		ACK	

To read the internal ITG-3200 device registers, the master first transmits the start condition (S), followed by the I<sup>2</sup>C address and the write bit (0). At the 9<sup>th</sup> clock cycle (when clock is high), the ITG acknowledges the transfer. The master then writes the register address that is going to be read. Upon receiving the ACK signal from the ITG-3200, the master transmits a start signal followed by the slave address and read bit. As a result, the ITG-3200 sends an ACK signal and the data. The communication ends with a not acknowledge (NACK) signal and a stop bit from master. The NACK condition is defined such that the SDA line remains high at the 9<sup>th</sup> clock cycle. To read multiple bytes of data, the master can output an acknowledge signal (ACK) instead of a not acknowledge (NACK) signal. In this case, the ITG-3200 automatically increments the register address and outputs data from the appropriate register. The following figures show single and two-byte read sequences.

**Single-Byte Read Sequence**

Master	S	AD+W		RA		S	AD+R			NACK	P
Slave			ACK		ACK			ACK	DATA		

**Burst Read Sequence**

Master	S	AD+W		RA		S	AD+R			ACK		NACK	P
Slave			ACK		ACK			ACK	DATA		DATA		



**I<sup>2</sup>C Terms**

Signal	Description
S	Start Condition: SDA goes from high to low while SCL is high
AD	Slave I <sup>2</sup> C address
W	Write bit (0)
R	Read bit (1)
ACK	Acknowledge: SDA line is low while the SCL line is high at the 9 <sup>th</sup> clock cycle
NACK	Not-Acknowledge: SDA line stays high at the 9 <sup>th</sup> clock cycle
RA	ITG-3200 internal register address
DATA	Transmit or received data
P	Stop condition: SDA going from low to high while SCL is high

Preliminary

## 7 Assembly

This section provides general guidelines for assembling InvenSense Micro Electro-Mechanical Systems (MEMS) gyros packaged in Quad Flat No leads package (QFN) surface mount integrated circuits.

### 7.1 Orientation

The diagram below shows the orientation of the axes of sensitivity and the polarity of rotation. Note the pin 1 identifier (•) in the figure.

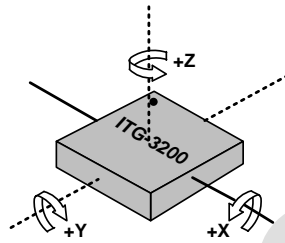

**Orientation of Axes of Sensitivity and Polarity of Rotation**



**7.3 PCB Design Guidelines:**

The Pad Diagram using a JEDEC type extension with solder rising on the outer edge is shown below. The Pad Dimensions Table shows pad sizing (mean dimensions) recommended for the MPU-30X0 product.

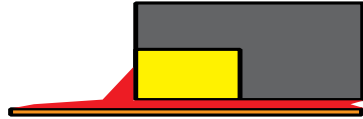

JEDEC type extension with solder rising on outer edge

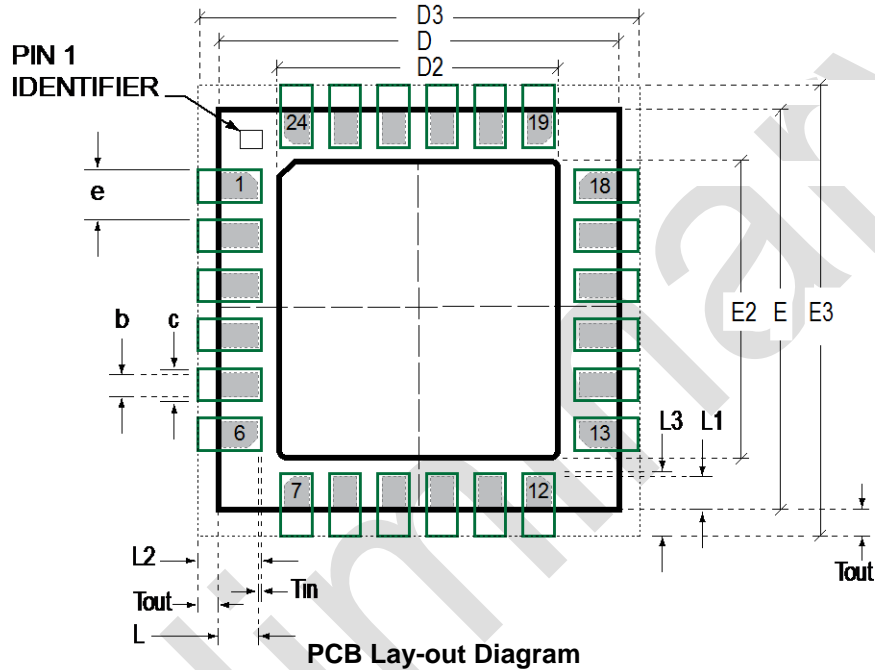

SYMBOLS	DIMENSIONS IN MILLIMETERS	NOM
Nominal Package I/O Pad Dimensions		
e	Pad Pitch	0.50
b	Pad Width	0.25
L	Pad Length	0.35
L1	Pad Length	0.40
D	Package Width	4.00
E	Package Length	4.00
D2	Exposed Pad Width	3.00
E2	Exposed Pad Length	2.80
I/O Land Design Dimensions (Guidelines)		
D3	I/O Pad Extent Width	4.80
E3	I/O Pad Extent Length	4.80
c	Land Width	0.35
Tout	Outward Extension	0.40
Tin	Inward Extension	0.05
L2	Land Length	0.80
L3	Land Length	0.85

**PCB Dimensions Table (for PCB Lay-out Diagram)**

## 7.4 Assembly Precautions

### 7.4.1 Gyroscope Surface Mount Guidelines

InvenSense MEMS Gyros sense rate of rotation. In addition, gyroscopes sense mechanical stress coming from the printed circuit board (PCB). This PCB stress can be minimized by adhering to certain design rules:

When using MEMS gyroscope components in plastic packages, PCB mounting and assembly can cause package stress. This package stress in turn can affect the output offset and its value over a wide range of temperatures. This stress is caused by the mismatch between the Coefficient of Linear Thermal Expansion (CTE) of the package material and the PCB. Care must be taken to avoid package stress due to mounting.

Traces connected to pads should be as symmetric as possible. Maximizing symmetry and balance for pad connection will help component self alignment and will lead to better control of solder paste reduction after reflow.

Any material used in the surface mount assembly process of the MEMS gyroscope should be free of restricted RoHS elements or compounds. Pb-free solders should be used for assembly.

### 7.4.2 Exposed Die Pad Precautions

The ITG-3200 has very low active and standby current consumption. The exposed die pad is not required for heat sinking, and should not be soldered to the PCB. Failure to adhere to this rule can induce performance changes due to package thermo-mechanical stress. There is no electrical connection between the pad and the CMOS.

### 7.4.3 Trace Routing

Routing traces or vias under the gyro package such that they run under the exposed die pad is prohibited. Routed active signals may harmonically couple with the gyro MEMS devices, compromising gyro response. These devices are designed with the drive frequencies as follows: X =  $33\pm 3\text{kHz}$ , Y =  $30\pm 3\text{kHz}$ , and Z =  $27\pm 3\text{kHz}$ . To avoid harmonic coupling don't route active signals in non-shielded signal planes directly below, or above the gyro package. Note: For best performance, design a ground plane under the e-pad to reduce PCB signal noise from the board on which the gyro device is mounted. If the gyro device is stacked under an adjacent PCB board, design a ground plane directly above the gyro device to shield active signals from the adjacent PCB board.

### 7.4.4 Component Placement

Do not place large insertion components such as keyboard or similar buttons, connectors, or shielding boxes at a distance of less than 6 mm from the MEMS gyro. Maintain generally accepted industry design practices for component placement near the ITG-3200 to prevent noise coupling and thermo-mechanical stress.

### 7.4.5 PCB Mounting and Cross-Axis Sensitivity

Orientation errors of the gyroscope mounted to the printed circuit board can cause cross-axis sensitivity in which one gyro responds to rotation about another axis. For example, the X-axis gyroscope may respond to rotation about the Y or Z axes. The orientation mounting errors are illustrated in the figure below.

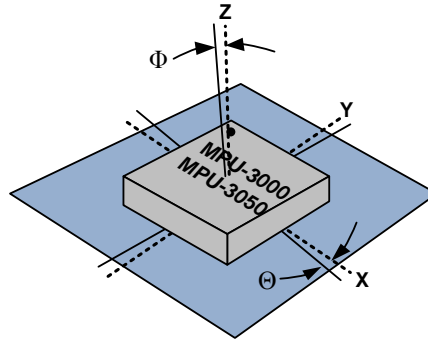

**Package Gyro Axes ( - - - ) Relative to PCB Axes ( — ) with Orientation Errors (  $\Theta$  and  $\Phi$  )**

The table below shows the cross-axis sensitivity of the gyroscope for a given orientation error.

**Cross-Axis Sensitivity vs. Orientation Error**

Orientation Error ( $\theta$ or $\Phi$ )	Cross-Axis Sensitivity ( $\sin\theta$ or $\sin\Phi$ )
0°	0%
0.5°	0.87%
1°	1.75%

The specification for cross-axis sensitivity in Section **Error! Reference source not found.** includes the effect of the die orientation error with respect to the package.

**7.4.6 MEMS Handling Instructions**

MEMS (Micro Electro-Mechanical Systems) are a time-proven, robust technology used in hundreds of millions of consumer, automotive and industrial products. MEMS devices consist of microscopic moving mechanical structures. They differ from conventional IC products, even though they can be found in similar packages. Therefore, MEMS devices require different handling precautions than conventional ICs prior to mounting onto printed circuit boards (PCBs).

The ITG-3200 gyroscope has been qualified to a shock tolerance of 10,000g. InvenSense packages its gyroscopes as it deems proper for protection against normal handling and shipping. It recommends the following handling precautions to prevent potential damage.

- Do not drop individually packaged gyroscopes, or trays of gyroscopes onto hard surfaces. Components placed in trays could be subject to *g*-forces in excess of 10,000g if dropped.
- Printed circuit boards that incorporate mounted gyroscopes should not be separated by manually snapping apart. This could also create *g*-forces in excess of 10,000g.

**7.4.7 ESD Considerations**

Establish and use ESD-safe handling precautions when unpacking and handling ESD-sensitive devices.

- Store ESD sensitive devices in ESD safe containers until ready for use. The Tape-and-Reel moisture-sealed bag is an ESD approved barrier. The best practice is to keep the units in the original moisture sealed bags until ready for assembly.
- Restrict all device handling to ESD protected work areas that measure less than 200V static charge. Ensure that all workstations and personnel are properly grounded to prevent ESD.

**7.4.8 Reflow Specification**

**Qualification Reflow:** The ITG-3200 gyroscope was qualified in accordance with IPC/JEDEC J-STD-020D.01. This standard classifies proper packaging, storage and handling in order to avoid subsequent thermal and mechanical damage during the solder reflow attachment phase of assembly. The classification specifies a sequence consisting of a bake cycle, a moisture soak cycle in a temperature humidity oven, followed by three solder reflow cycles and functional testing for qualification. All temperatures refer to the topside of the QFN package, as measured on the package body surface. The peak solder reflow classification temperature requirement is (260 +5/-0°C) for lead-free soldering of components measuring less than 1.6 mm in thickness.

**Production Reflow:** Check the recommendations of your solder manufacturer. For optimum results, production solder reflow processes should reduce exposure to high temperatures, and use lower ramp-up and ramp-down rates than those used in the component qualification profile shown for reference below.

Production reflow should never exceed the maximum constraints listed in the table and shown in the figure below. These constraints were used for the qualification profile, and represent the maximum tolerable ratings for the device.

**Maximum Temperature IR / Convection Solder Reflow Curve Used for Qualification**

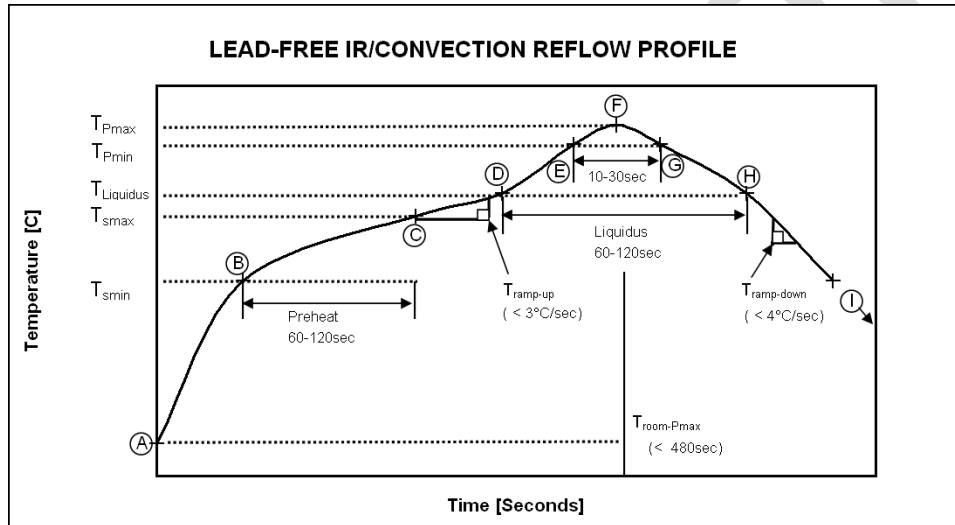

**Temperature Set Points for IR / Convection Reflow Corresponding to Figure Above**

Step	Setting	CONSTRAINTS		
		Temp (°C)	Time (sec)	Rate (°C/sec)
A	T <sub>room</sub>	25		
B	T <sub>Smin</sub>	150		
C	T <sub>Smax</sub>	200	60 < t <sub>BC</sub> < 120	
D	T <sub>Liquidus</sub>	217		Γ(T <sub>Liquidus</sub> -T <sub>Pmax</sub> ) < 3
E	T <sub>Pmin</sub> [255°C, 260°C]	255		Γ(T <sub>Liquidus</sub> -T <sub>Pmax</sub> ) < 3
F	T <sub>Pmax</sub> [260°C, 265°C]	260	t <sub>AF</sub> < 480	Γ(T <sub>Liquidus</sub> -T <sub>Pmax</sub> ) < 3
G	T <sub>Pmin</sub> [255°C, 260°C]	255	10 < t <sub>EG</sub> < 30	Γ(T <sub>Pmax</sub> -T <sub>Liquidus</sub> ) < 4
H	T <sub>Liquidus</sub>	217	60 < t <sub>DH</sub> < 120	
I	T <sub>room</sub>	25		

Note: For users T<sub>Pmax</sub> must not exceed the classification temperature (260°C).  
 For suppliers T<sub>Pmax</sub> must equal or exceed the classification temperature.



### 7.4.9 Storage Specifications

The storage specification of the ITG-3200 gyroscope conforms to IPC/JEDEC J-STD-020D.01 Moisture Sensitivity Level (MSL) 3.

Calculated shelf-life in moisture-sealed bag	12 months -- Storage conditions: <40°C and <90% RH
After opening moisture-sealed bag	168 hours -- Storage conditions: ambient ≤30°C at 60%RH

### 7.5 Package Marking Specification

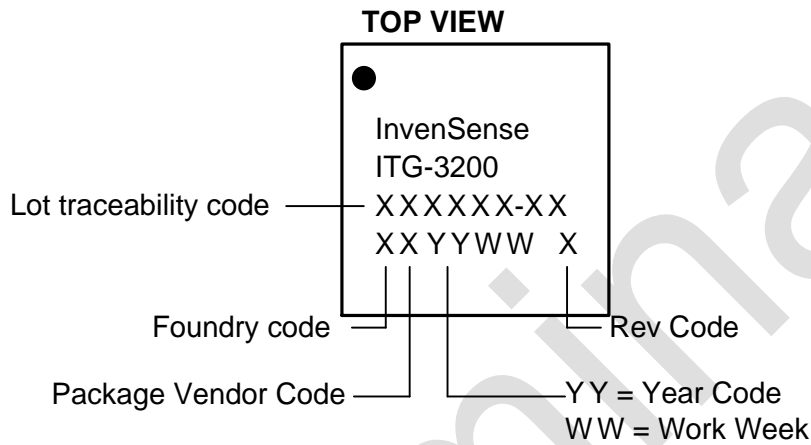

### Package Marking Specification

7.6 Tape & Reel Specification

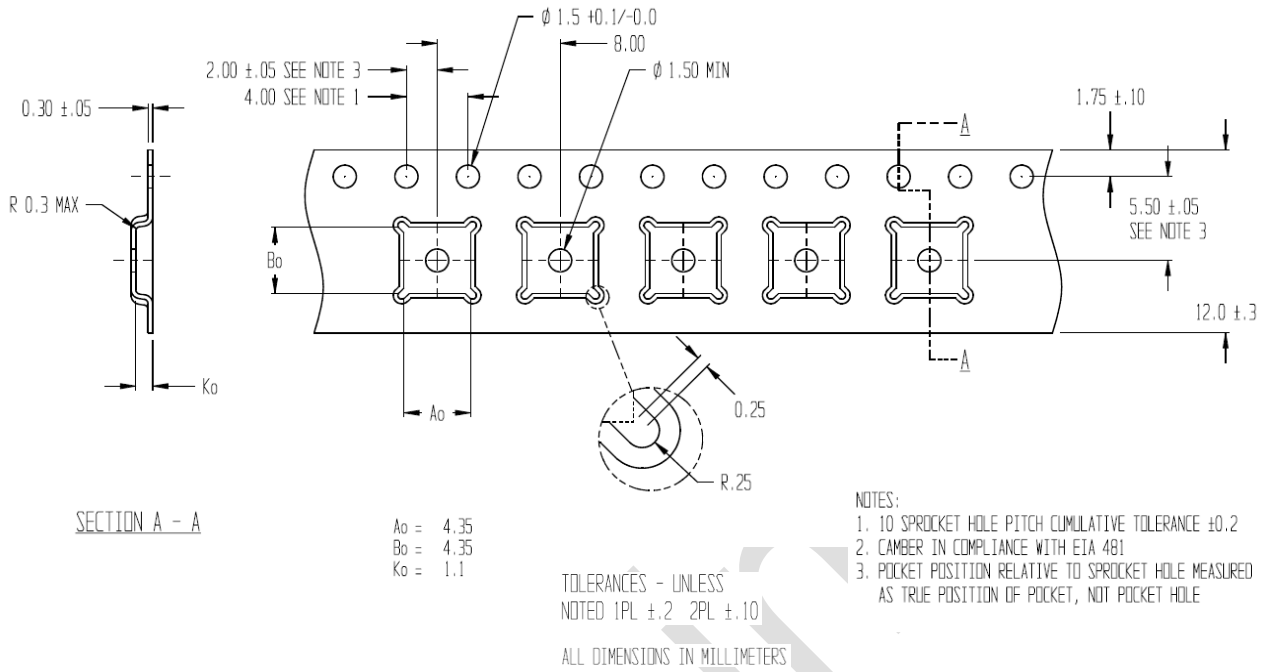

Tape Dimensions

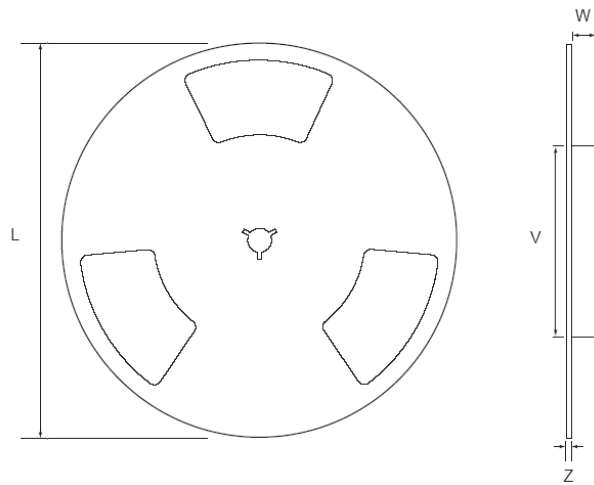

Reel Outline Drawing

Reel Dimensions and Package Size

PKG SIZE	REEL (mm)			
	L	V	W	Z
4x4	330	100	13.2	2.2

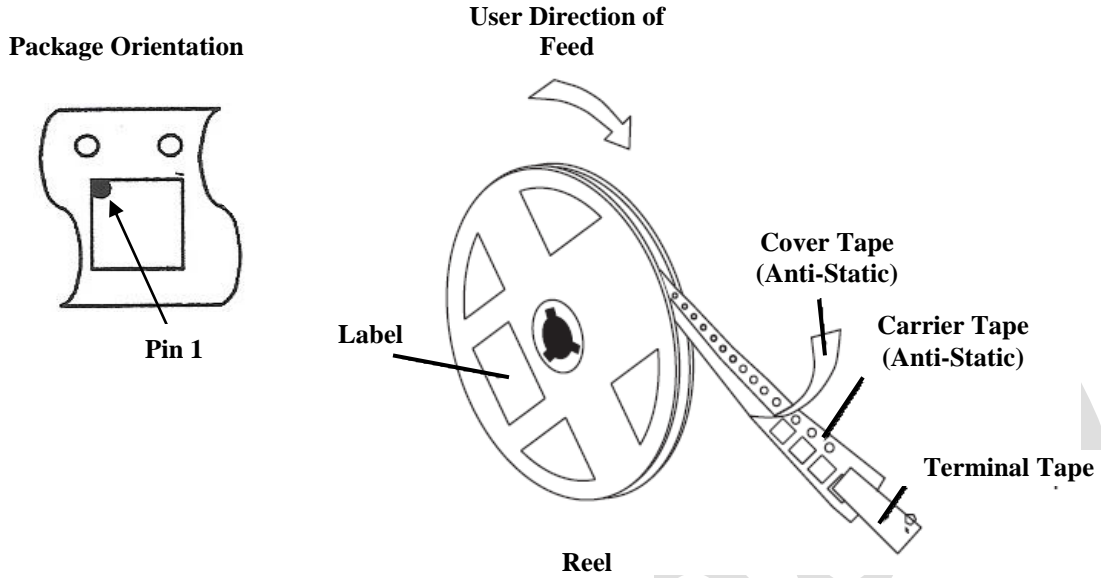

**Tape and Reel Specification**

**Reel Specifications**

Quantity Per Reel	5,000
Reels per Box	1
Boxes Per Carton (max)	3 full pizza boxes packed in the center of the carton, buffered by two empty pizza boxes (front and back).
Pcs/Carton (max)	15,000

**7.7 Label**

<b>InvenSense</b>		
DEVICE (IP) : ITG-3200	P.O.:	REEL QTY (Q) : 5000
LOT 1 (1T) : 123456-A	D/C (D) : 1234	QTY (Q) : 5000
LOT 2 (1T) :	D/C (D) :	QTY (Q) :
Reel Date : 13/10/09		QC STAMP



Location of Label

7.8 Packaging

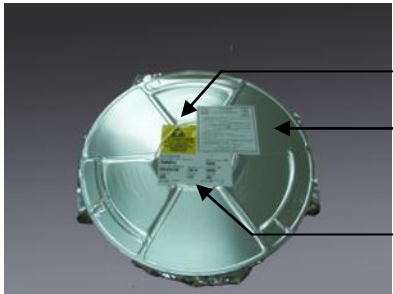

Moisture Barrier Bag With Labels

ESD Anti-static Label  
 Moisture-Sensitivity Caution Label  
 Tape & Reel Barcode Label

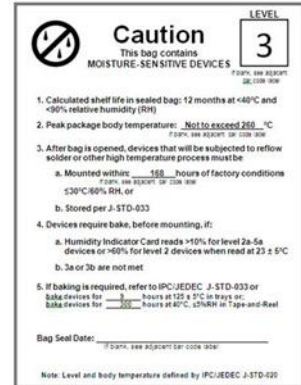

Moisture-Sensitive Caution Label



Reel in Box



Box with Tape & Reel Label

Preliminary



## 8 Reliability

### 8.1 Qualification Test Policy

Before InvenSense products are released for production, they complete a series of qualification tests. The Qualification Test Plan for the ITG-3200 followed the JEDEC JESD47G.01 Standard, "Stress-Test-Driven Qualification of Integrated Circuits." The individual tests are described below.

### 8.2 Qualification Test Plan

#### Accelerated Life Tests

TEST	Method/Condition	Lot Quantity	Sample / Lot	Acc / Reject Criteria
High Temperature Operating Life (HTOL/LFR)	JEDEC JESD22-A108C, Dynamic, 3.63V biased, $T_j > 125^\circ\text{C}$ [read-points 168, 500, 1000 hours]	3	77	(0/1)
Highly Accelerated Stress Test <sup>(1)</sup> (HAST)	JEDEC JESD22-A118 Condition A, $130^\circ\text{C}$ , 85%RH, 33.3 psia., unbiased, [read-point 96 hours]	3	77	(0/1)
High Temperature Storage Life (HTS)	JEDEC JESD22-A103C, Cond. A, $125^\circ\text{C}$ , Non-Biased Bake [read-points 168, 500, 1000 hours]	3	77	(0/1)

#### Device Component Level Tests

TEST	Method/Condition	Lot Quantity	Sample / Lot	Acc / Reject Criteria
ESD-HBM	JEDEC JESD22-A114F, (1.5KV)	1	3	(0/1)
ESD-MM	JEDEC JESD22-A115-A, (200V)	1	3	(0/1)
Latch Up	JEDEC JESD78B Class II (2), $125^\circ\text{C}$ ; Level B $\pm 60\text{mA}$	1	6	(0/1)
Mechanical Shock	JEDEC JESD22-B104C, Mil-Std-883H, method 2002.5, Cond. E, $10,000g's$ , 0.2ms, $\pm X, Y, Z$ – 6 directions, 5 times/direction	3	30	(0/1)
Vibration	JEDEC JESD22-B103B, Variable Frequency (random), Cond. B, 5-500Hz, $X, Y, Z$ – 4 times/direction	3	5	(0/1)
Temperature Cycling (TC) <sup>(1)</sup>	JEDEC JESD22-A104D Condition N, [ $-40^\circ\text{C}$ to $+85^\circ\text{C}$ ], Soak Mode 2 [5'], 100 cycles	3	77	(0/1)

#### Board Level Tests

TEST	Method/Condition	Lot Quantity	Sample / Lot	Acc / Reject Criteria
Board Mechanical Shock	JEDEC JESD22-B104C, Mil-Std-883H, method 2002.5, Cond. E, $10000g's$ , 0.2ms, $+X, Y, Z$ – 6 directions, 5 times/direction	1	5	(0/1)
Board Temperature Cycling (TC) <sup>(1)</sup>	JEDEC JESD22-A104D Condition N, [ $-40^\circ\text{C}$ to $+85^\circ\text{C}$ ], Soak Mode 2 [5'], 100 cycles	1	40	(0/1)

(1) Tests are preceded by MSL3 Preconditioning in accordance with JEDEC JESD22-A113F



## 9 Environmental Compliance

The ITG-3200 is RoHS and Green Compliant.

The ITG-3200 is in full environmental compliance as evidenced in report HS-ITG-3200A, Materials Declaration Data Sheet.

### Environmental Declaration Disclaimer:

InvenSense believes this environmental information to be correct but cannot guarantee accuracy or completeness. Conformity documents for the above component constitutes are on file. InvenSense subcontracts manufacturing and the information contained herein is based on data received from vendors and suppliers, which has not been validated by InvenSense.

This information furnished by InvenSense is believed to be accurate and reliable. However, no responsibility is assumed by InvenSense for its use, or for any infringements of patents or other rights of third parties that may result from its use. Specifications are subject to change without notice. InvenSense reserves the right to make changes to this product, including its circuits and software, in order to improve its design and/or performance, without prior notice. InvenSense makes no warranties, neither expressed nor implied, regarding the information and specifications contained in this document. InvenSense assumes no responsibility for any claims or damages arising from information contained in this document, or from the use of products and services detailed therein. This includes, but is not limited to, claims or damages based on the infringement of patents, copyrights, mask work and/or other intellectual property rights.

Certain intellectual property owned by InvenSense and described in this document is patent protected. No license is granted by implication or otherwise under any patent or patent rights of InvenSense. This publication supersedes and replaces all information previously supplied. Trademarks that are registered trademarks are the property of their respective companies. InvenSense sensors should not be used or sold in the development, storage, production or utilization of any conventional or mass-destructive weapons or for any other weapons or life threatening applications, as well as in any other life critical applications such as medical equipment, transportation, aerospace and nuclear instruments, undersea equipment, power plant equipment, disaster prevention and crime prevention equipment.

InvenSense® is a registered trademark of InvenSense, Inc. ITG™, ITG-3200™, MotionApps™, MPU™, MotionProcessing Unit™, MotionProcessor™, MotionProcessing™, MotionFusion™, MPU-3050™, MPU-6050™, IMU-3000™ are trademarks of InvenSense, Inc.

©2011 InvenSense, Inc. All rights reserved.

