



InvenSense Inc.

1197 Borregas Ave, Sunnyvale, CA 94089 U.S.A.
Tel: +1 (408) 988-7339 Fax: +1 (408) 988-8104
Website: www.invensense.com

Document Number: PS-MPU-6000A-00
Revision: 2.2
Release Date: 08/05/2011

MPU-6000 and MPU-6050 Product Specification Revision 2.2

CONTENTS

| | | |
|----------|--|-----------|
| 1 | REVISION HISTORY | 5 |
| 2 | PURPOSE AND SCOPE | 6 |
| 3 | PRODUCT OVERVIEW | 8 |
| 3.1 | MPU-60X0 OVERVIEW | 8 |
| 3.2 | SOFTWARE SOLUTIONS..... | 9 |
| 4 | APPLICATIONS..... | 11 |
| 5 | FEATURES | 12 |
| 5.1 | GYROSCOPE FEATURES..... | 12 |
| 5.2 | ACCELEROMETER FEATURES | 12 |
| 5.3 | ADDITIONAL FEATURES | 12 |
| 5.4 | MOTIONPROCESSING..... | 13 |
| 5.5 | CLOCKING | 13 |
| 6 | ELECTRICAL CHARACTERISTICS | 14 |
| 6.1 | GYROSCOPE SPECIFICATIONS | 14 |
| 6.2 | ACCELEROMETER SPECIFICATIONS..... | 15 |
| 6.3 | ELECTRICAL AND OTHER COMMON SPECIFICATIONS..... | 16 |
| 6.4 | ELECTRICAL SPECIFICATIONS, CONTINUED | 17 |
| 6.5 | ELECTRICAL SPECIFICATIONS, CONTINUED | 18 |
| 6.6 | ELECTRICAL SPECIFICATIONS, CONTINUED | 19 |
| 6.7 | I ² C TIMING CHARACTERIZATION..... | 20 |
| 6.8 | SPI TIMING CHARACTERIZATION (MPU-6000 ONLY) | 21 |
| 6.9 | ABSOLUTE MAXIMUM RATINGS | 22 |
| 7 | APPLICATIONS INFORMATION | 23 |
| 7.1 | PIN OUT AND SIGNAL DESCRIPTION | 23 |
| 7.2 | TYPICAL OPERATING CIRCUIT..... | 24 |
| 7.3 | BILL OF MATERIALS FOR EXTERNAL COMPONENTS | 24 |
| 7.4 | RECOMMENDED POWER-ON PROCEDURE | 25 |
| 7.5 | BLOCK DIAGRAM | 26 |
| 7.6 | OVERVIEW | 26 |
| 7.7 | THREE-AXIS MEMS GYROSCOPE WITH 16-BIT ADCs AND SIGNAL CONDITIONING..... | 27 |
| 7.8 | THREE-AXIS MEMS ACCELEROMETER WITH 16-BIT ADCs AND SIGNAL CONDITIONING | 27 |
| 7.9 | DIGITAL MOTION PROCESSOR | 27 |
| 7.10 | PRIMARY I ² C AND SPI SERIAL COMMUNICATIONS INTERFACES | 27 |



| | | |
|-----------|---|-----------|
| 7.11 | AUXILIARY I ² C SERIAL INTERFACE | 28 |
| 7.12 | SELF-TEST | 29 |
| 7.13 | MPU-60X0 SOLUTION FOR 9-AXIS SENSOR FUSION USING I ² C INTERFACE | 30 |
| 7.14 | MPU-6000 USING SPI INTERFACE | 31 |
| 7.15 | INTERNAL CLOCK GENERATION | 32 |
| 7.16 | SENSOR DATA REGISTERS | 32 |
| 7.17 | FIFO | 32 |
| 7.18 | INTERRUPTS | 33 |
| 7.19 | DIGITAL-OUTPUT TEMPERATURE SENSOR | 33 |
| 7.20 | BIAS AND LDO | 33 |
| 7.21 | CHARGE PUMP | 33 |
| 8 | PROGRAMMABLE INTERRUPTS..... | 34 |
| 8.1 | FREE FALL, MOTION, AND ZERO MOTION SIGNAL PATHS | 35 |
| 8.2 | FREE FALL INTERRUPT..... | 36 |
| 8.3 | MOTION INTERRUPT..... | 36 |
| 8.4 | ZERO MOTION INTERRUPT..... | 37 |
| 9 | DIGITAL INTERFACE | 38 |
| 9.1 | I ² C AND SPI (MPU-6000 ONLY) SERIAL INTERFACES | 38 |
| 9.2 | I ² C INTERFACE | 38 |
| 9.3 | I ² C COMMUNICATIONS PROTOCOL..... | 38 |
| 9.4 | I ² C TERMS | 41 |
| 9.5 | SPI INTERFACE (MPU-6000 ONLY) | 42 |
| 10 | SERIAL INTERFACE CONSIDERATIONS (MPU-6050)..... | 43 |
| 10.1 | MPU-6050 SUPPORTED INTERFACES..... | 43 |
| 10.2 | LOGIC LEVELS | 43 |
| 10.3 | LOGIC LEVELS DIAGRAM FOR AUX_VDDIO = 0..... | 44 |
| 10.4 | LOGIC LEVELS DIAGRAM FOR AUX_VDDIO = 1..... | 45 |
| 11 | ASSEMBLY | 46 |
| 11.1 | ORIENTATION OF AXES | 46 |
| 11.2 | PACKAGE DIMENSIONS | 47 |
| 11.3 | PCB DESIGN GUIDELINES:..... | 48 |
| 11.4 | ASSEMBLY PRECAUTIONS | 49 |
| 11.5 | STORAGE SPECIFICATIONS..... | 53 |
| 11.6 | PACKAGE MARKING SPECIFICATION..... | 53 |



11.7 TAPE & REEL SPECIFICATION54

11.8 LABEL55

11.9 PACKAGING.....56

12 RELIABILITY57

12.1 QUALIFICATION TEST POLICY57

12.2 QUALIFICATION TEST PLAN57

13 ENVIRONMENTAL COMPLIANCE.....58

PRELIMINARY



1 Revision History

| Revision Date | Revision | Description |
|---------------|----------|--|
| 11/24/2010 | 1.0 | Initial Release |
| 05/19/2011 | 2.0 | <p>Modified wording for clarity</p> <p>Modified low-power accelerometer mode's wake-up frequencies and current consumption values (Sections 5.2 & 6.3)</p> <p>Removed Gyro Self-Test (Sections 5.1, 6.1, 7.6 & 7.12)</p> <p>Sec. 3.2 Added Software Solutions section</p> <p>Sec. 6.1 Clarified Gyro Full Scale Range selection</p> <p>Sec. 6.1 Added Gyro LPF Response for consistency</p> <p>Sec. 6.2 Modified accelerometer sensitivity values and changed units from mg/LSB to LSB/mg for consistency</p> <p>Sec. 6.2 Added temperature range to conditions for accelerometer sensitivity change vs temperature specification</p> <p>Sec. 6.2 Modified accelerometer Zero-G Output parameters</p> <p>Sec. 6.2 Modified accelerometer Power Spectral Density value</p> <p>Sec. 6.2 Modified accelerometer LPF Response for consistency</p> <p>Sec. 6.3 Modified Temperature Offset value for Temperature Sensor</p> <p>Sec. 6.3 Modified Temperature Sensor sensitivity</p> <p>Sec. 6.4 Added CLKOUT Digital Out specification</p> <p>Sec. 6.6 Specified Max PLL Settling time of 10ms</p> <p>Sec. 6.9 Clarified Latch-up Absolute Maximum Rating</p> <p>Sec. 7 Moved Sections for Internal Clock Generation, Sensor Data Registers, FIFO, Interrupts, Digital-Output Temperature Sensor, Bias and LDO, and Charge Pump to Section 7</p> <p>Sec. 7.1 Specified FSYNC to be connected to GND if unused</p> <p>Sec. 7.2 Changed C3 Capacitance from 10nF to 2.2nF in diagram</p> <p>Sec. 7.3 Removed 10nF Capacitor from C3,BOM External Components</p> <p>Sec. 7.4 Modified Power Up Sequence notes for clarity</p> <p>Sec. 7.5 Clarified self-test & Charge Pump configuration in diagram</p> <p>Sec. 7.11 Documented MPU-60X0 data register access capability in Pass-Through Mode</p> <p>Sec. 7.14 Added use of Slaves 0-3 for both reading from and writing to external sensors</p> <p>Sec. 8 Removed DMP Interrupt and PLL Interrupt</p> <p>Sec. 8.2 Updated FF_THR to 2mg increments</p> <p>Sec. 8.3 Updated MOT_THR to 2mg increments</p> <p>Sec. 8.4 Specified ZRMOT_THR increments as 2mg</p> <p>Sec. 10.3 Modified diagram for clarity & added clarification for CLKOUT</p> <p>Sec. 10.4 Modified diagram for clarity & added clarification for CLKOUT</p> <p>Sec. 11 Modified assembly rules, packaging information, and packaging labels</p> <p>Sec. 12.2 Clarified Latch-up Absolute Maximum Rating</p> |



MPU-6000/MPU-6050 Product Specification

Document Number: PS-MPU-6000A-00
Revision: 2.2
Release Date: 08/05/2011

| | | |
|---------|-----|---|
| 7/28/11 | 2.1 | Sec. 6.4 Edited Supply current numbers for different modes |
| 8/05/11 | 2.2 | Unit for Accelerometer sensitivity changed from LSB/mg to LSB/g |

PRELIMINARY



2 Purpose and Scope

This product specification provides preliminary information regarding the electrical specification and design related information for the MPU-6000™ and MPU-6050™ Motion Processing Unit™, collectively called the MPU-60X0™ or MPU™.

Electrical characteristics are based upon design analysis and simulation results only. Specifications are subject to change without notice. Final specifications will be updated based upon characterization of production silicon. For references to register map and descriptions of individual registers, please refer to the MPU-6000/MPU-6050 Register Map and Register Descriptions document.

PRELIMINARY

3 Product Overview

3.1 MPU-60X0 Overview

The MPU-60X0 Motion Processing Unit is the world's first motion processing solution with integrated 9-Axis sensor fusion using its field-proven and proprietary MotionFusion™ engine for handset and tablet applications, game controllers, motion pointer remote controls, and other consumer devices. The MPU-60X0 has an embedded 3-axis MEMS gyroscope, a 3-axis MEMS accelerometer, and a Digital Motion Processor™ (DMP™) hardware accelerator engine with an auxiliary I²C port that interfaces to 3rd party digital sensors such as magnetometers. When connected to a 3-axis magnetometer, the MPU-60X0 delivers a complete 9-axis MotionFusion output to its primary I²C or SPI port (SPI is available on MPU-6000 only). The MPU-60X0 combines acceleration and rotational motion plus heading information into a single data stream for the application. This MotionProcessing™ technology integration provides a smaller footprint and has inherent cost advantages compared to discrete gyroscope plus accelerometer solutions. The MPU-60X0 is also designed to interface with multiple non-inertial digital sensors, such as pressure sensors, on its auxiliary I²C port. The MPU-60X0 is a 2nd generation motion processor and is footprint compatible with the MPU-30X0 family.

The MPU-60X0 features three 16-bit analog-to-digital converters (ADCs) for digitizing the gyroscope outputs and three 16-bit ADCs for digitizing the accelerometer outputs. For precision tracking of both fast and slow motions, the parts feature a user-programmable gyroscope full-scale range of ± 250 , ± 500 , ± 1000 , and $\pm 2000^\circ/\text{sec}$ (dps) and a user-programmable accelerometer full-scale range of $\pm 2g$, $\pm 4g$, $\pm 8g$, and $\pm 16g$.

An on-chip 1024 Byte FIFO buffer helps lower system power consumption by allowing the system processor to read the sensor data in bursts and then enter a low-power mode as the MPU collects more data. With all the necessary on-chip processing and sensor components required to support many motion-based use cases, the MPU-60X0 uniquely supports a variety of advanced motion-based applications entirely on-chip. The MPU-60X0 thus enables low-power MotionProcessing in portable applications with reduced processing requirements for the system processor. By providing an integrated MotionFusion output, the DMP in the MPU-60X0 offloads the intensive MotionProcessing computation requirements from the system processor, minimizing the need for frequent polling of the motion sensor output.

Communication with all registers of the device is performed using either I²C at 400kHz or SPI at 1MHz (MPU-6000 only). For applications requiring faster communications, the sensor and interrupt registers may be read using SPI at 20MHz (MPU-6000 only). Additional features include an embedded temperature sensor and an on-chip oscillator with $\pm 1\%$ variation over the operating temperature range.

By leveraging its patented and volume-proven Nasiri-Fabrication platform, which integrates MEMS wafers with companion CMOS electronics through wafer-level bonding, InvenSense has driven the MPU-60X0 package size down to a revolutionary footprint of 4x4x0.9mm (QFN), while providing the highest performance, lowest noise, and the lowest cost semiconductor packaging required for handheld consumer electronic devices. The part features a robust 10,000g shock tolerance, and has programmable low-pass filters for the gyroscopes, accelerometers, and the on-chip temperature sensor.

For power supply flexibility, the MPU-60X0 operates from VDD power supply voltages of $2.5V \pm 5\%$, $3.0V \pm 5\%$, or $3.3V \pm 5\%$. Additionally, the MPU-6050 provides a VLOGIC reference pin (in addition to its analog supply pin: VDD), which sets the logic levels of its I²C interface. The VLOGIC voltage may be $1.8V \pm 5\%$ or VDD.

The MPU-6000 and MPU-6050 are identical, except that the MPU-6050 supports the I²C serial interface only, and has a separate VLOGIC reference pin. The MPU-6000 supports both I²C and SPI interfaces and has a single supply pin, VDD, which is both the device's logic reference supply and the analog supply for the part. The table below outlines these differences:

**Primary Differences between MPU-6000 and MPU-6050**

| Part / Item | MPU-6000 | MPU-6050 |
|-----------------------------|-------------------------------|-------------------------------|
| VDD | 2.5V±5%, 3.0V±5%, or 3.3V±5%. | 2.5V±5%, 3.0V±5%, or 3.3V±5%. |
| VLOGIC | n/a | 1.71V to VDD |
| Serial Interfaces Supported | I ² C, SPI | I ² C |
| Pin 8 | /CS | VLOGIC |
| Pin 9 | AD0/SDO | AD0 |
| Pin 23 | SCL/SCLK | SCL |
| Pin 24 | SDA/SDI | SDA |

3.2 Software Solutions

This section describes the MotionApps™ software solutions included with the InvenSense MPU (Motion Processing Unit) and IMU (Inertial Measurement Unit) product families. Please note that the products within the IDG, IXZ, and ITG families do not include these software solutions.

The MotionApps Platform is a complete software solution that in combination with the InvenSense IMU and MPU MotionProcessor families delivers robust, well-calibrated 6-axis and/or 9-axis sensor fusion data using its field proven and proprietary MotionFusion engine. Solution packages are available for smartphones and tablets as well as for embedded microcontroller-based devices.

The MotionApps Platform provides a turn-key solution for developers and accelerates time-to-market. It consists of complex 6/9-axis sensor fusion algorithms, robust multi-sensor calibration, a proven software architecture for Android and other leading operating systems, and a flexible power management scheme.

The MotionApps Platform is integrated within the middleware of the target OS (the sensor framework), and also provides a kernel device driver to interface with the physical device. This directly benefits application developers by providing a cohesive set of APIs and a well-defined sensor data path in the user-space.



The table below describes the MotionApps software solutions included with the InvenSense MPU and IMU product families.

InvenSense MotionProcessor Devices and Included MotionApps Software

| Feature | Included Software | | | | Notes |
|--|------------------------------|--|------------------------------|--|--|
| | MotionApps | Embedded MotionApps | MotionApps Lite | Embedded MotionApps Lite | |
| Part Number | MPU-3050 MPU-6050 | | IMU-3000 | | |
| Processor Type | Mobile Application Processor | 8/16/32-bit Microcontroller | Mobile Application Processor | 8/16/32-bit Microcontroller | |
| Applications | Smartphones, tablets | TV remotes, health/fitness, toys, other embedded | Smartphones, tablets | TV remotes, health/fitness, toys, other embedded | |
| 6-Axis MotionFusion | Yes | | Yes | | < 2% Application Processor load using on-chip Digital Motion Processor (DMP). Reduces processing requirements for embedded applications |
| 9-Axis MotionFusion | Yes | | No | | |
| Gyro Bias Calibration | Yes | | Yes | | No-Motion calibration and temperature calibration |
| 3 rd Party Compass Cal API | Yes | | No | | Integrates 3 rd party compass libraries |
| Gyro-Assisted Compass Calibration (Fast Heading) | Yes | | No | | Quick compass calibration using gyroscope |
| Magnetic Anomaly Rejection (Improved Heading) | Yes | | No | | Uses gyro heading data when magnetic anomaly is detected |

The table below lists recommended documentation for the MotionApps software solutions.

Software Documentation

| Platform | MotionApps and MotionApps Lite | Embedded MotionApps and Embedded MotionApps Lite |
|------------------------|--|--|
| Software Documentation | <ul style="list-style-type: none"> • Installation Guide for Linux and Android MotionApps Platform, v1.9 or later • MPL Functional Specifications | <ul style="list-style-type: none"> • Embedded MotionApps Platform User Guide, v3.0 or later • Embedded MPL Functional Specifications |

For more information about the InvenSense MotionApps Platform, please visit the Developer's Corner or consult your local InvenSense Sales Representative.



4 Applications

- *BlurFree*[™] technology (for Video/Still Image Stabilization)
- *AirSign*[™] technology (for Security/Authentication)
- *TouchAnywhere*[™] technology (for “no touch” UI Application Control/Navigation)
- *MotionCommand*[™] technology (for Gesture Short-cuts)
- Motion-enabled game and application framework
- InstantGesture[™] iG[™] gesture recognition
- Location based services, points of interest, and dead reckoning
- Handset and portable gaming
- Motion-based game controllers
- 3D remote controls for Internet connected DTVs and set top boxes, 3D mice
- Wearable sensors for health, fitness and sports
- Toys

PRELIMINARY

5 Features

5.1 Gyroscope Features

The triple-axis MEMS gyroscope in the MPU-60X0 includes a wide range of features:

- Digital-output X-, Y-, and Z-Axis angular rate sensors (gyroscopes) with a user-programmable full-scale range of ± 250 , ± 500 , ± 1000 , and $\pm 2000^\circ/\text{sec}$
- External sync signal connected to the FSYNC pin supports image, video and GPS synchronization
- Integrated 16-bit ADCs enable simultaneous sampling of gyros
- Enhanced bias and sensitivity temperature stability reduces the need for user calibration
- Improved low-frequency noise performance
- Digitally-programmable low-pass filter
- Gyroscope operating current: 5mA
- Standby current: 5 μ A
- Factory calibrated sensitivity scale factor

5.2 Accelerometer Features

The triple-axis MEMS accelerometer in MPU-60X0 includes a wide range of features:

- Digital-output triple-axis accelerometer with a programmable full scale range of $\pm 2g$, $\pm 4g$, $\pm 8g$ and $\pm 16g$
- Integrated 16-bit ADCs enable simultaneous sampling of accelerometers while requiring no external multiplexer
- Accelerometer normal operating current: 500 μ A
- Low power accelerometer mode current: 10 μ A at 1.25Hz, 20 μ A at 5Hz, 60 μ A at 20Hz, 110 μ A at 40Hz
- Orientation detection and signaling
- Tap detection
- User-programmable interrupts
- Free-fall interrupt
- High-G interrupt
- Zero Motion/Motion interrupt
- User self-test

5.3 Additional Features

The MPU-60X0 includes the following additional features:

- 9-Axis MotionFusion by the on-chip Digital Motion Processor (DMP)
- Auxiliary master I²C bus for reading data from external sensors (e.g., magnetometer)
- 5.5mA operating current when all 6 motion sensing axes and the DMP are enabled
- VDD supply voltages of 2.5V \pm 5%, 3.0V \pm 5%, 3.3V \pm 5%
- Flexible VLOGIC reference voltage supports multiple I²C interface voltages (MPU-6050 only)
- Smallest and thinnest QFN package for portable devices: 4x4x0.9mm
- Minimal cross-axis sensitivity between the accelerometer and gyroscope axes
- 1024 byte FIFO buffer reduces power consumption by allowing host processor to read the data in bursts and then go into a low-power mode as the MPU collects more data
- Digital-output temperature sensor
- User-programmable digital filters for gyroscope, accelerometer, and temp sensor
- 10,000 g shock tolerant
- 400kHz Fast Mode I²C for communicating with all registers
- 1MHz SPI serial interface for communicating with all registers (MPU-6000 only)

- 20MHz SPI serial interface for reading sensor and interrupt registers (MPU-6000 only)
- MEMS structure hermetically sealed and bonded at wafer level
- RoHS and Green compliant

5.4 MotionProcessing

- Internal Digital Motion Processing™ (DMP™) engine supports 3D MotionProcessing and gesture recognition algorithms
- The MPU-60X0 collects gyroscope and accelerometer data while synchronizing data sampling at a user defined rate. The total dataset obtained by the MPU-60X0 includes 3-Axis gyroscope data, 3-Axis accelerometer data, and temperature data. The MPU's calculated output to the system processor can also include heading data from a digital 3-axis third party magnetometer.
- The FIFO buffers the complete data set, reducing timing requirements on the system processor by allowing the processor burst read the FIFO data. After burst reading the FIFO data, the system processor can save power by entering a low-power sleep mode while the MPU collects more data.
- Programmable interrupt supports features such as gesture recognition, panning, zooming, scrolling, zero-motion detection, tap detection, and shake detection
- Digitally-programmable low-pass filters
- Low-power pedometer functionality allows the host processor to sleep while the DMP maintains the step count.

5.5 Clocking

- On-chip timing generator $\pm 1\%$ frequency variation over full temperature range
- Optional external clock inputs of 32.768kHz or 19.2MHz

PRELIMINARY



6 Electrical Characteristics

6.1 Gyroscope Specifications

VDD = 2.5V±5%, 3.0V±5%, or 3.3V±5%, VLOGIC (MPU-6050 only) = 1.8V±5% or VDD, T_A = 25°C

| PARAMETER | CONDITIONS | MIN | TYP | MAX | UNITS | NOTES |
|---|------------------------------|-----|-------|-------|-----------|-------|
| GYROSCOPE SENSITIVITY | | | | | | |
| Full-Scale Range | FS_SEL=0 | | ±250 | | °/s | |
| | FS_SEL=1 | | ±500 | | °/s | |
| | FS_SEL=2 | | ±1000 | | °/s | |
| | FS_SEL=3 | | ±2000 | | °/s | |
| Gyroscope ADC Word Length | | | 16 | | bits | |
| Sensitivity Scale Factor | FS_SEL=0 | | 131 | | LSB/(°/s) | |
| | FS_SEL=1 | | 65.5 | | LSB/(°/s) | |
| | FS_SEL=2 | | 32.8 | | LSB/(°/s) | |
| | FS_SEL=3 | | 16.4 | | LSB/(°/s) | |
| Sensitivity Scale Factor Tolerance | 25°C | -3 | | +3 | % | |
| Sensitivity Scale Factor Variation Over Temperature | | | ±2 | | % | |
| Nonlinearity | Best fit straight line; 25°C | | 0.2 | | % | |
| Cross-Axis Sensitivity | | | ±2 | | % | |
| GYROSCOPE ZERO-RATE OUTPUT (ZRO) | | | | | | |
| Initial ZRO Tolerance | 25°C | | ±20 | | °/s | |
| ZRO Variation Over Temperature | -40°C to +85°C | | ±20 | | °/s | |
| Power-Supply Sensitivity (1-10Hz) | Sine wave, 100mVpp; VDD=2.5V | | 0.2 | | °/s | |
| Power-Supply Sensitivity (10 - 250Hz) | Sine wave, 100mVpp; VDD=2.5V | | 0.2 | | °/s | |
| Power-Supply Sensitivity (250Hz - 100kHz) | Sine wave, 100mVpp; VDD=2.5V | | 4 | | °/s | |
| Linear Acceleration Sensitivity | Static | | 0.1 | | °/s/g | |
| GYROSCOPE NOISE PERFORMANCE | FS_SEL=0 | | | | | |
| Total RMS Noise | DLPFCFG=2 (100Hz) | | 0.05 | | °/s-rms | |
| Low-frequency RMS noise | Bandwidth 1Hz to10Hz | | 0.033 | | °/s-rms | |
| Rate Noise Spectral Density | At 10Hz | | 0.005 | | °/s/√Hz | |
| GYROSCOPE MECHANICAL FREQUENCIES | | | | | | |
| X-Axis | | 30 | 33 | 36 | kHz | |
| Y-Axis | | 27 | 30 | 33 | kHz | |
| Z-Axis | | 24 | 27 | 30 | kHz | |
| LOW PASS FILTER RESPONSE | | | | | | |
| | Programmable Range | 5 | | 256 | Hz | |
| OUTPUT DATA RATE | | | | | | |
| | Programmable | 4 | | 8,000 | Hz | |
| GYROSCOPE START-UP TIME | DLPFCFG=0 | | | | | |
| ZRO Settling | to ±1% of Final | | 30 | | ms | |



6.2 Accelerometer Specifications

VDD = 2.5V±5%, 3.0V±5%, or 3.3V±5%, VLOGIC (MPU-6050 only) = 1.8V±5% or VDD, T_A = 25°C

| PARAMETER | CONDITIONS | MIN | TYP | MAX | UNITS | NOTES |
|-------------------------------------|--|-----|-------|-------|--------|-------|
| ACCELEROMETER SENSITIVITY | | | | | | |
| Full-Scale Range | AFS_SEL=0 | | ±2 | | g | |
| | AFS_SEL=1 | | ±4 | | g | |
| | AFS_SEL=2 | | ±8 | | g | |
| | AFS_SEL=3 | | ±16 | | g | |
| ADC Word Length | Output in two's complement format | | 16 | | bits | |
| Sensitivity Scale Factor | AFS_SEL=0 | | 8192 | | LSB/g | |
| | AFS_SEL=1 | | 4096 | | LSB/g | |
| | AFS_SEL=2 | | 2048 | | LSB/g | |
| | AFS_SEL=3 | | 1024 | | LSB/g | |
| Initial Calibration Tolerance | | | ±3 | | % | |
| Sensitivity Change vs. Temperature | AFS_SEL=0, -40°C to +85°C | | ±0.02 | | %/°C | |
| Nonlinearity | Best Fit Straight Line | | 0.5 | | % | |
| Cross-Axis Sensitivity | | | ±2 | | % | |
| ZERO-G OUTPUT | | | | | | |
| Initial Calibration Tolerance | X & Y Axes | | ±50 | | mg | |
| | Z Axis | | ±200 | | mg | |
| Zero-G Level Change vs. Temperature | X & Y Axes, 0°C to 70°C | | ±35 | | mg | |
| | Z Axis, 0°C to 70°C | | ±60 | | mg | |
| SELF TEST RESPONSE | | | | | | |
| | X, Y, and Z Axes | | 0.5 | | g | |
| NOISE PERFORMANCE | | | | | | |
| Power Spectral Density | X & Y Axes, @10Hz, AFS_SEL=0 & ODR=1kHz | | 400 | | μg/√Hz | |
| | Z Axis, @10Hz, AFS_SEL=0 & ODR=1kHz | | 600 | | μg/√Hz | |
| LOW PASS FILTER RESPONSE | | | | | | |
| | Programmable Range | 5 | | 260 | Hz | |
| OUTPUT DATA RATE | | | | | | |
| | Programmable Range | 4 | | 1,000 | Hz | |



6.3 Electrical and Other Common Specifications

VDD = 2.5V±5%, 3.0V±5%, or 3.3V±5%, VLOGIC (MPU-6050 only) = 1.8V±5% or VDD, T_A = 25°C

| PARAMETER | CONDITIONS | MIN | TYP | MAX | Units | Notes |
|--|--|------|------------|-----|--------|-------|
| TEMPERATURE SENSOR | | | | | | |
| Range | | | -40 to +85 | | °C | |
| Sensitivity | Untrimmed | | 340 | | LSB/°C | |
| Temperature Offset | 35°C | | -521 | | LSB | |
| Linearity | Best fit straight line (-40°C to +85°C) | | ±1 | | °C | |
| VDD POWER SUPPLY | | | | | | |
| Operating Voltages | | | 2.5±5% | | V | |
| | | | 3.0±5% | | V | |
| | | | 3.3±5% | | V | |
| Normal Operating Current | Gyroscope + Accelerometer + DMP | | 3.9 | | mA | |
| | Gyroscope+Accelerometer (DMP disabled) | | 3.8 | | mA | |
| | Gyroscope + DMP (Accelerometer disabled) | | 3.7 | | mA | |
| | Gyroscope only (DMP & Accelerometer disabled) | | 3.6 | | mA | |
| Accelerometer Low Power Mode Current | Accelerometer only (DMP & Gyroscope disabled) | | 500 | | µA | |
| | 1.25 Hz update rate | | 10 | | µA | |
| | 5 Hz update rate | | 20 | | µA | |
| | 20 Hz update rate | | 60 | | µA | |
| | 40 Hz update rate | | 110 | | µA | |
| Full-Chip Idle Mode Supply Current | | | 5 | | µA | |
| Power Supply Ramp Rate | Monotonic ramp. Ramp rate is 10% to 90% of the final value | | | 100 | ms | |
| VLOGIC REFERENCE VOLTAGE | | | | | | |
| Voltage Range | MPU-6050 only VLOGIC must be ≤VDD at all times | 1.71 | | VDD | V | |
| Power Supply Ramp Rate | Monotonic ramp. Ramp rate is 10% to 90% of the final value | | | 3 | ms | |
| Normal Operating Current | | | 100 | | µA | |
| START-UP TIME FOR REGISTER READ/WRITE | | | | | | |
| | | | 20 | 100 | ms | |
| TEMPERATURE RANGE | | | | | | |
| Specified Temperature Range | Performance parameters are not applicable beyond Specified Temperature Range | -40 | | +85 | °C | |



6.4 Electrical Specifications, Continued

VDD = 2.5V±5%, 3.0V±5%, or 3.3V±5%, VLOGIC (MPU-6050 only) = 1.8V±5% or VDD, TA = 25°C

| PARAMETER | CONDITIONS | MIN | TYP | MAX | Units | Notes |
|---|--|------------|----------|------------|-------|-------|
| SERIAL INTERFACE | | | | | | |
| SPI Operating Frequency, All Registers Read/Write | MPU-6000 only, Low Speed Characterization | | 100 ±10% | | kHz | |
| | MPU-6000 only, High Speed Characterization | | 1 ±10% | | MHz | |
| SPI Operating Frequency, Sensor and Interrupt Registers Read Only | MPU-6000 only | | 20 ±10% | | MHz | |
| | All registers, Fast-mode | | | 400 | kHz | |
| I ² C Operating Frequency | All registers, Standard-mode | | | 100 | kHz | |
| I²C ADDRESS | | | | | | |
| | AD0 = 0 | | 1101000 | | | |
| | AD0 = 1 | | 1101001 | | | |
| DIGITAL INPUTS (SDI/SDA, AD0, SCLK/SCL, FSYNC, /CS, CLKIN) | | | | | | |
| V _{IH} , High Level Input Voltage | MPU-6000 | 0.7*VDD | | | V | |
| | MPU-6050 | 0.7*VLOGIC | | | V | |
| V _{IL} , Low Level Input Voltage | MPU-6000 | | | 0.3*VDD | V | |
| | MPU-6050 | | | 0.3*VLOGIC | V | |
| C _i , Input Capacitance | | | < 5 | | pF | |
| DIGITAL OUTPUT (SDO, INT) | | | | | | |
| V _{OH} , High Level Output Voltage | R _{LOAD} =1MΩ; MPU-6000 | 0.9*VDD | | | V | |
| | R _{LOAD} =1MΩ; MPU-6050 | 0.9*VLOGIC | | | V | |
| V _{OL1} , LOW-Level Output Voltage | R _{LOAD} =1MΩ; MPU-6000 | | | 0.1*VDD | V | |
| | R _{LOAD} =1MΩ; MPU-6050 | | | 0.1*VLOGIC | V | |
| V _{OL,INT1} , INT Low-Level Output Voltage | OPEN=1, 0.3mA sink Current | | | 0.1 | V | |
| Output Leakage Current | OPEN=1 | | 100 | | nA | |
| t _{INT} , INT Pulse Width | LATCH_INT_EN=0 | | 50 | | μs | |
| DIGITAL OUTPUT (CLKOUT) | | | | | | |
| V _{OH} , High Level Output Voltage | R _{LOAD} =1MΩ | 0.9*VDD | | | V | |
| V _{OL1} , LOW-Level Output Voltage | R _{LOAD} =1MΩ | | | 0.1*VDD | V | |



6.5 Electrical Specifications, Continued

Typical Operating Circuit of Section 7.2, VDD = 2.5V±5%, 3.0V±5%, or 3.3V±5%, VLOGIC (MPU-6050 only) = 1.8V±5% or VDD, TA = 25°C

| Parameters | Conditions | Typical | Units | Notes |
|--|--|-----------------------------|-------|-------|
| Primary I²C I/O (SCL, SDA) | | | | |
| V _{IL} , LOW-Level Input Voltage | MPU-6000 | -0.5 to 0.3*VDD | V | |
| V _{IH} , HIGH-Level Input Voltage | MPU-6000 | 0.7*VDD to VDD + 0.5V | V | |
| V _{hys} , Hysteresis | MPU-6000 | 0.1*VDD | V | |
| V _{IL} , LOW Level Input Voltage | MPU-6050 | -0.5V to 0.3*VLOGIC | V | |
| V _{IH} , HIGH-Level Input Voltage | MPU-6050 | 0.7*VLOGIC to VLOGIC + 0.5V | V | |
| V _{hys} , Hysteresis | MPU-6050 | 0.1*VLOGIC | V | |
| V _{OL1} , LOW-Level Output Voltage | 3mA sink current | 0 to 0.4 | V | |
| I _{OL} , LOW-Level Output Current | V _{OL} = 0.4V | 3 | mA | |
| | V _{OL} = 0.6V | 5 | mA | |
| Output Leakage Current | | 100 | nA | |
| t _{of} , Output Fall Time from V _{IHmax} to V _{ILmax} | C _b bus capacitance in pF | 20+0.1C _b to 250 | ns | |
| C _I , Capacitance for Each I/O pin | | < 10 | pF | |
| Auxiliary I²C I/O (AUX_CL, AUX_DA) | MPU-6050: AUX_VDDIO=0 | | | |
| V _{IL} , LOW-Level Input Voltage | | -0.5V to 0.3*VLOGIC | V | |
| V _{IH} , HIGH-Level Input Voltage | | 0.7*VLOGIC to VLOGIC + 0.5V | V | |
| V _{hys} , Hysteresis | | 0.1*VLOGIC | V | |
| V _{OL1} , LOW-Level Output Voltage | VLOGIC > 2V; 1mA sink current | 0 to 0.4 | V | |
| V _{OL3} , LOW-Level Output Voltage | VLOGIC < 2V; 1mA sink current | 0 to 0.2*VLOGIC | V | |
| I _{OL} , LOW-Level Output Current | V _{OL} = 0.4V | 1 | mA | |
| | V _{OL} = 0.6V | 1 | mA | |
| Output Leakage Current | | 100 | nA | |
| t _{of} , Output Fall Time from V _{IHmax} to V _{ILmax} | C _b bus capacitance in pF | 20+0.1C _b to 250 | ns | |
| C _I , Capacitance for Each I/O pin | | < 10 | pF | |
| Auxiliary I²C I/O (AUX_CL, AUX_DA) | MPU-6050: AUX_VDDIO=1; MPU-6000 | | | |
| V _{IL} , LOW-Level Input Voltage | | -0.5 to 0.3*VDD | V | |
| V _{IH} , HIGH-Level Input Voltage | | 0.7*VDD to VDD+0.5V | V | |
| V _{hys} , Hysteresis | | 0.1*VDD | V | |
| V _{OL1} , LOW-Level Output Voltage | 1mA sink current | 0 to 0.4 | V | |
| I _{OL} , LOW-Level Output Current | V _{OL} = 0.4V | 1 | mA | |
| | V _{OL} = 0.6V | 1 | mA | |
| Output Leakage Current | | 100 | nA | |
| t _{of} , Output Fall Time from V _{IHmax} to V _{ILmax} | C _b bus cap. in pF | 20+0.1C _b to 250 | ns | |
| C _I , Capacitance for Each I/O pin | | < 10 | pF | |



6.6 Electrical Specifications, Continued

Typical Operating Circuit of Section 7.2, VDD = 2.5V±5%, 3.0V±5%, or 3.3V±5%, VLOGIC (MPU-6050 only) = 1.8V±5% or VDD, TA = 25°C

| Parameters | Conditions | Min | Typical | Max | Units | Notes |
|--------------------------------------|--|-----|------------|------|-------|-------|
| INTERNAL CLOCK SOURCE | CLK_SEL=0,1,2,3 | | | | | |
| Gyroscope Sample Rate, Fast | DLPFCFG=0 SAMPLERATEDIV = 0 | | 8 | | kHz | |
| Gyroscope Sample Rate, Slow | DLPFCFG=1,2,3,4,5, or 6 SAMPLERATEDIV = 0 | | 1 | | kHz | |
| Accelerometer Sample Rate | | | 1 | | kHz | |
| Reference Clock Output | CLKOUTEN = 1 | | 1.024 | | MHz | |
| Clock Frequency Initial Tolerance | CLK_SEL=0, 25°C | -5 | | +5 | % | |
| | CLK_SEL=1,2,3; 25°C | -1 | | +1 | % | |
| Frequency Variation over Temperature | CLK_SEL=0 | | -15 to +10 | | % | |
| | CLK_SEL=1,2,3 | | ±1 | | % | |
| PLL Settling Time | CLK_SEL=1,2,3 | | 1 | 10 | ms | |
| EXTERNAL 32.768kHz CLOCK | CLK_SEL=4 | | | | | |
| External Clock Frequency | | | 32.768 | | kHz | |
| External Clock Allowable Jitter | Cycle-to-cycle rms | | 1 to 2 | | µs | |
| Gyroscope Sample Rate, Fast | DLPFCFG=0 SAMPLERATEDIV = 0 | | 8.192 | | kHz | |
| Gyroscope Sample Rate, Slow | DLPFCFG=1,2,3,4,5, or 6 SAMPLERATEDIV = 0 | | 1.024 | | kHz | |
| Accelerometer Sample Rate | | | 1.024 | | kHz | |
| Reference Clock Output | CLKOUTEN = 1 | | 1.0486 | | MHz | |
| PLL Settling Time | | | 1 | 10 | ms | |
| EXTERNAL 19.2MHz CLOCK | CLK_SEL=5 | | | | | |
| External Clock Frequency | | | 19.2 | | MHz | |
| Gyroscope Sample Rate | Full programmable range | 3.9 | | 8000 | Hz | |
| Gyroscope Sample Rate, Fast Mode | DLPFCFG=0 SAMPLERATEDIV = 0 | | 8 | | kHz | |
| Gyroscope Sample Rate, Slow Mode | DLPFCFG=1,2,3,4,5, or 6 SAMPLERATEDIV = 0 | | 1 | | kHz | |
| Accelerometer Sample Rate | | | 1 | | kHz | |
| Reference Clock Output | CLKOUTEN = 1 | | 1.024 | | MHz | |
| PLL Settling Time | | | 1 | 10 | ms | |

6.7 I²C Timing Characterization

Typical Operating Circuit of Section 7.2, VDD = 2.5V±5%, 3.0V±5%, or 3.3V±5%, VLOGIC (MPU-6050 only) = 1.8V±5% or VDD, T_A = 25°C

| Parameters | Conditions | Min | Typical | Max | Units | Notes |
|---|--|---------------------------------|---------|-----|-------|-------|
| I²C TIMING | | I²C FAST-MODE | | | | |
| f _{SCL} , SCL Clock Frequency | | | | 400 | kHz | |
| t _{HD,STA} , (Repeated) START Condition Hold Time | | 0.6 | | | μs | |
| t _{LOW} , SCL Low Period | | 1.3 | | | μs | |
| t _{HIGH} , SCL High Period | | 0.6 | | | μs | |
| t _{SU,STA} , Repeated START Condition Setup Time | | 0.6 | | | μs | |
| t _{HD,DAT} , SDA Data Hold Time | | 0 | | | μs | |
| t _{SU,DAT} , SDA Data Setup Time | | 100 | | | ns | |
| t _r , SDA and SCL Rise Time | C _b bus cap. from 10 to 400pF | 20+0.1C _b | | 300 | ns | |
| t _f , SDA and SCL Fall Time | C _b bus cap. from 10 to 400pF | 20+0.1C _b | | 300 | ns | |
| t _{SU,STO} , STOP Condition Setup Time | | 0.6 | | | μs | |
| t _{BUF} , Bus Free Time Between STOP and START Condition | | 1.3 | | | μs | |
| C _b , Capacitive Load for each Bus Line | | | < 400 | | pF | |
| t _{VD,DAT} , Data Valid Time | | | | 0.9 | μs | |
| t _{VD,ACK} , Data Valid Acknowledge Time | | | | 0.9 | μs | |

Note: Timing Characteristics apply to both Primary and Auxiliary I²C Bus

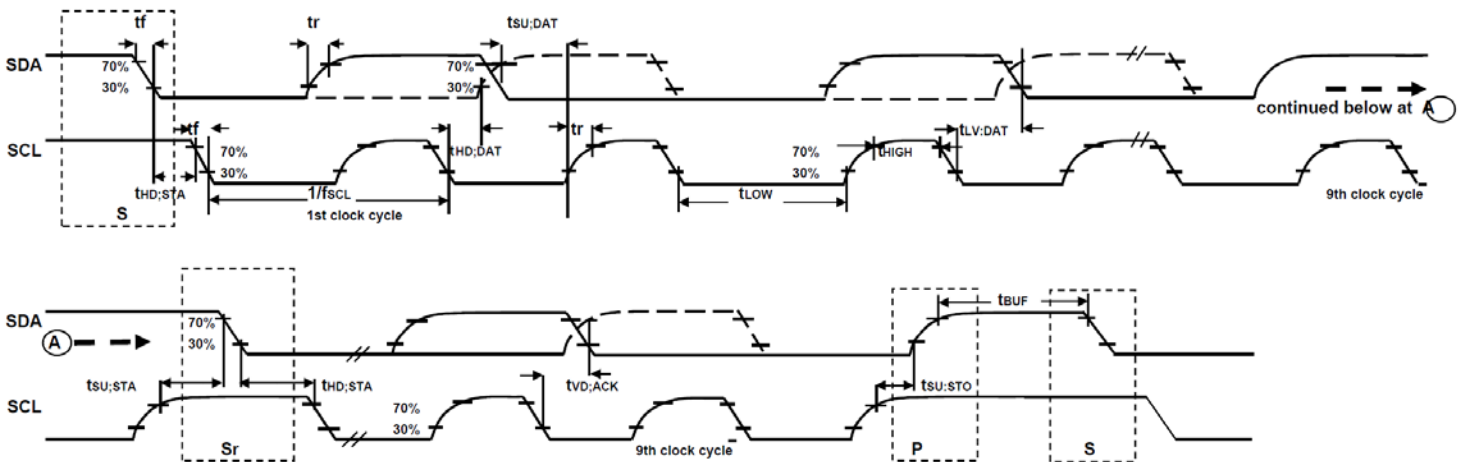

I²C Bus Timing cycle Diagram

6.8 SPI Timing Characterization (MPU-6000 only)

Typical Operating Circuit of Section 7.2, $V_{DD} = 2.5V \pm 5\%$, $3.0V \pm 5\%$, or $3.3V \pm 5\%$, VLOGIC (MPU-6050 only) = $1.8V \pm 5\%$ or V_{DD} , $T_A = -40^\circ\text{C}$ to $+85^\circ\text{C}$, unless otherwise noted.

| Parameters | Conditions | Min | Typical | Max | Units | Notes |
|---|--------------------------|-----|---------|-----|-------|-------|
| SPI TIMING | | | | | | |
| f_{SCLK} , SCLK Clock Frequency | | | | 1 | MHz | |
| t_{LOW} , SCLK Low Period | | 400 | | | ns | |
| t_{HIGH} , SCLK High Period | | 400 | | | ns | |
| $t_{SU,CS}$, CS Setup Time | | 8 | | | ns | |
| $t_{HD,CS}$, CS Hold Time | | 500 | | | ns | |
| $t_{SU,SDI}$, SDI Setup Time | | 11 | | | ns | |
| $t_{HD,SDI}$, SDI Hold Time | | 7 | | | ns | |
| $t_{VD,SDO}$, SDO Valid Time | $C_{load} = 20\text{pF}$ | | | 100 | ns | |
| $t_{HD,SDO}$, SDO Hold Time | $C_{load} = 20\text{pF}$ | 4 | | | ns | |
| $t_{DIS,SDO}$, SDO Output Disable Time | | | | 10 | ns | |

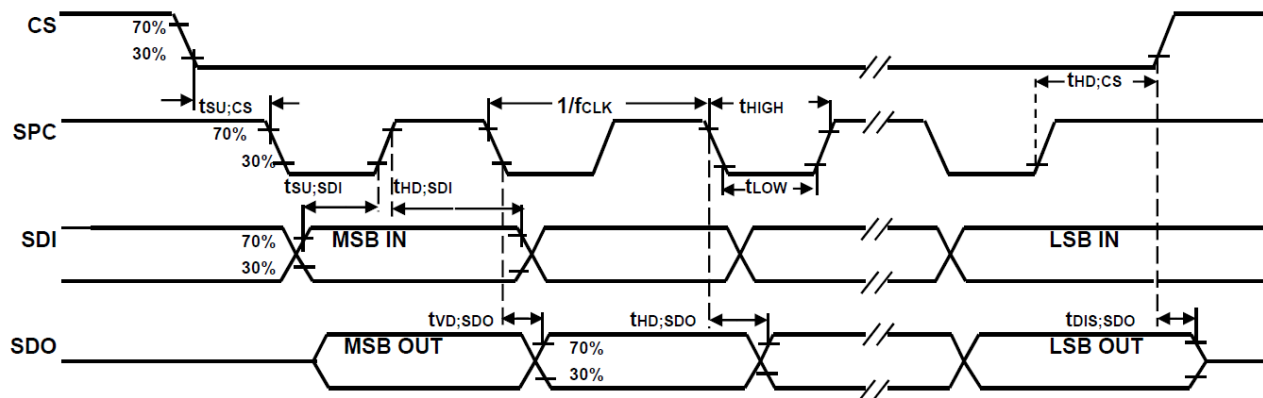

SPI Bus Timing Diagram

**6.9 Absolute Maximum Ratings**

Stress above those listed as “Absolute Maximum Ratings” may cause permanent damage to the device. These are stress ratings only and functional operation of the device at these conditions is not implied. Exposure to the absolute maximum ratings conditions for extended periods may affect device reliability.

| Parameter | Rating |
|--|---|
| Supply Voltage, VDD | -0.5V to +6V |
| VLOGIC Input Voltage Level (MPU-6050) | -0.5V to VDD + 0.5V |
| REGOUT | -0.5V to 2V |
| Input Voltage Level (CLKIN, AUX_DA, AD0, FSYNC, INT, SCL, SDA) | -0.5V to VDD + 0.5V |
| CPOUT (2.5V ≤ VDD ≤ 3.6V) | -0.5V to 30V |
| Acceleration (Any Axis, unpowered) | 10,000g for 0.3ms |
| Operating Temperature Range | -40°C to +105°C |
| Storage Temperature Range | -40°C to +125°C |
| Electrostatic Discharge (ESD) Protection | 2kV (HBM); 200V (MM) |
| Latch-up | JEDEC Class II (2), 125°C Level B, ±60mA |

7 Applications Information

7.1 Pin Out and Signal Description

| Pin Number | MPU-6000 | MPU-6050 | Pin Name | Pin Description |
|----------------------------|----------|----------|------------|--|
| 1 | Y | Y | CLKIN | Optional external reference clock input. Connect to GND if unused. |
| 6 | Y | Y | AUX_DA | I ² C master serial data, for connecting to external sensors |
| 7 | Y | Y | AUX_CL | I ² C Master serial clock, for connecting to external sensors |
| 8 | Y | | /CS | SPI chip select (0=SPI mode) |
| 8 | | Y | VLOGIC | Digital I/O supply voltage |
| 9 | Y | | AD0 / SDO | I ² C Slave Address LSB (AD0); SPI serial data output (SDO) |
| 9 | | Y | AD0 | I ² C Slave Address LSB (AD0) |
| 10 | Y | Y | REGOUT | Regulator filter capacitor connection |
| 11 | Y | Y | FSYNC | Frame synchronization digital input. Connect to GND if unused. |
| 12 | Y | Y | INT | Interrupt digital output (totem pole or open-drain) |
| 13 | Y | Y | VDD | Power supply voltage and Digital I/O supply voltage |
| 18 | Y | Y | GND | Power supply ground |
| 19, 21 | Y | Y | RESV | Reserved. Do not connect. |
| 20 | Y | Y | CPOUT | Charge pump capacitor connection |
| 22 | Y | Y | CLKOUT | System clock output |
| 23 | Y | | SCL / SCLK | I ² C serial clock (SCL); SPI serial clock (SCLK) |
| 23 | | Y | SCL | I ² C serial clock (SCL) |
| 24 | Y | | SDA / SDI | I ² C serial data (SDA); SPI serial data input (SDI) |
| 24 | | Y | SDA | I ² C serial data (SDA) |
| 2, 3, 4, 5, 14, 15, 16, 17 | Y | Y | NC | Not internally connected. May be used for PCB trace routing. |

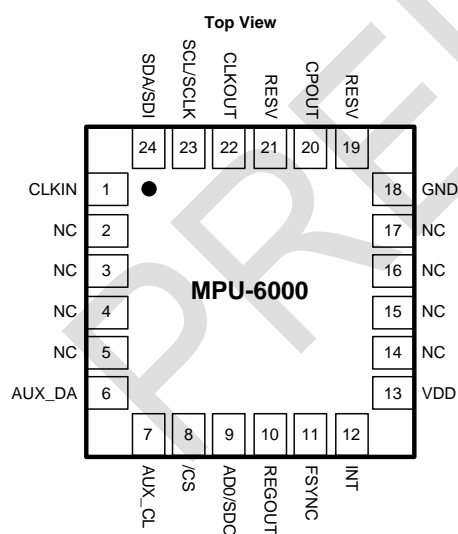

QFN Package
24-pin, 4mm x 4mm x 0.9mm

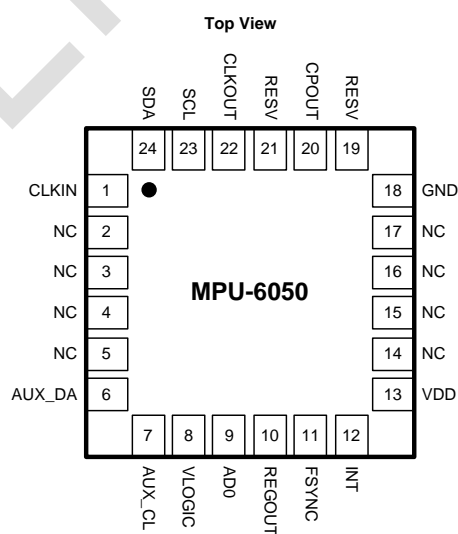

QFN Package
24-pin, 4mm x 4mm x 0.9mm

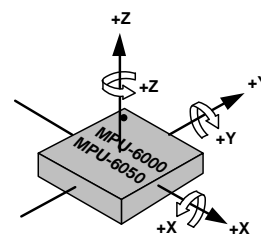

Orientation of Axes of Sensitivity and
Polarity of Rotation

7.2 Typical Operating Circuit

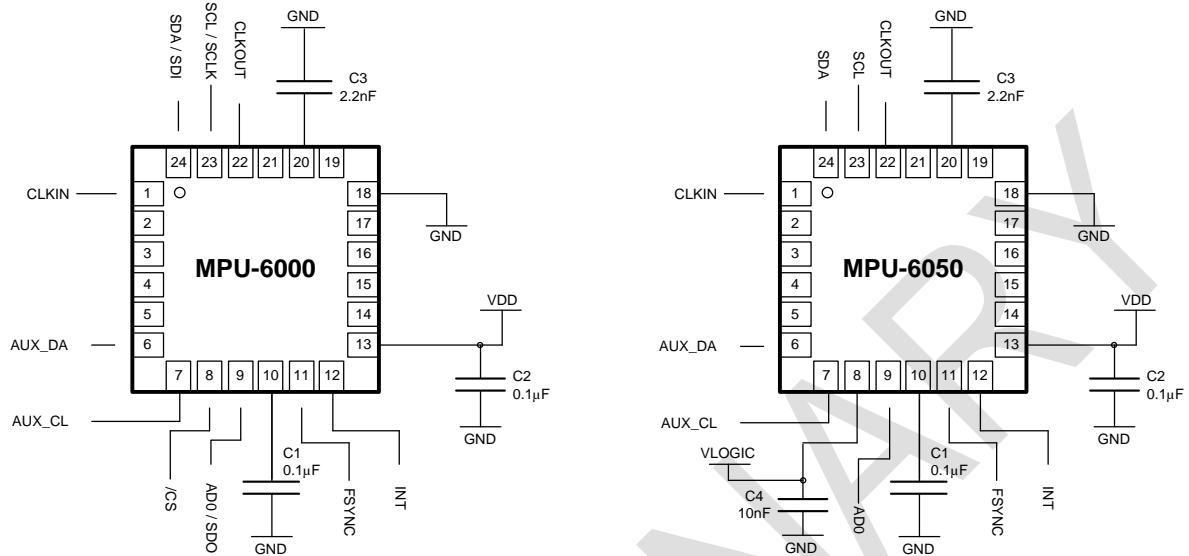

Typical Operating Circuits

7.3 Bill of Materials for External Components

| Component | Label | Specification | Quantity |
|-------------------------------------|-------|-------------------------------|----------|
| Regulator Filter Capacitor (Pin 10) | C1 | Ceramic, X7R, 0.1µF ±10%, 2V | 1 |
| VDD Bypass Capacitor (Pin 13) | C2 | Ceramic, X7R, 0.1µF ±10%, 4V | 1 |
| Charge Pump Capacitor (Pin 20) | C3 | Ceramic, X7R, 2.2nF ±10%, 50V | 1 |
| VLOGIC Bypass Capacitor (Pin 8) | C4* | Ceramic, X7R, 10nF ±10%, 4V | 1 |

* MPU-6050 Only.

7.4 Recommended Power-on Procedure

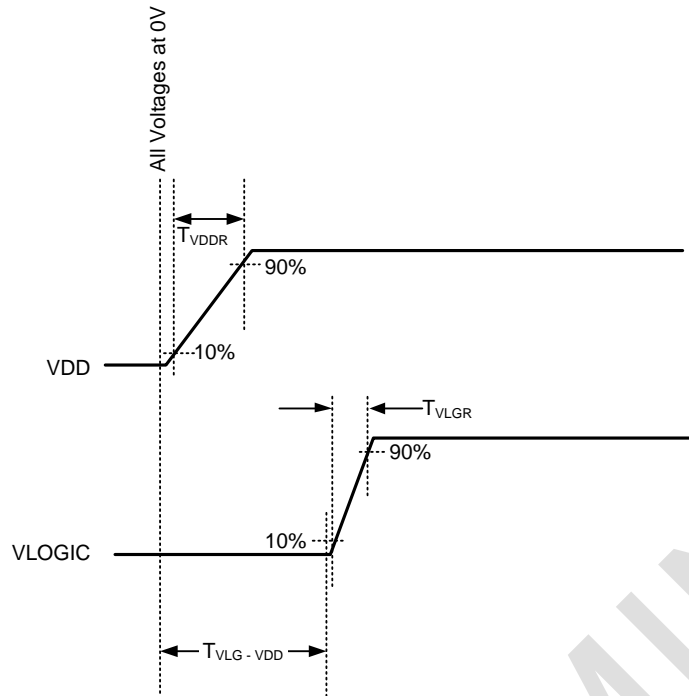

Power-Up Sequencing

1. VLOGIC amplitude must always be \leq VDD amplitude
2. T_{VDDR} is VDD rise time: Time for VDD to rise from 10% to 90% of its final value
3. T_{VDDR} is $\leq 100\text{ms}$
4. T_{VLGR} is VLOGIC rise time: Time for VLOGIC to rise from 10% to 90% of its final value
5. T_{VLGR} is $\leq 3\text{ms}$
6. $T_{VLG-VDD}$ is the delay from the start of VDD ramp to the start of VLOGIC rise
7. $T_{VLG-VDD}$ is ≥ 0
8. VDD and VLOGIC must be monotonic ramps

7.5 Block Diagram

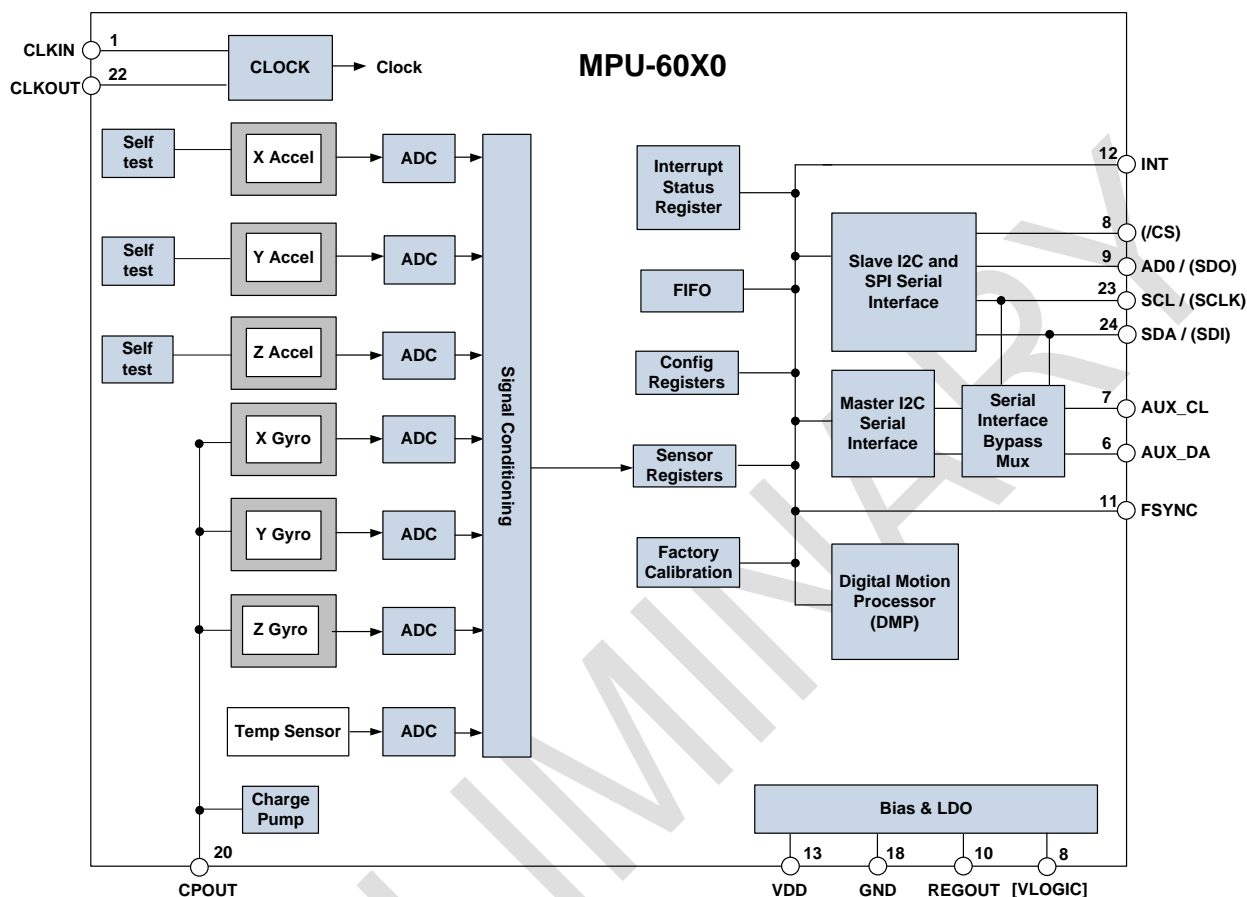

Note: Pin names in round brackets () apply only to MPU-6000
 Pin names in square brackets [] apply only to MPU-6050

7.6 Overview

The MPU-60X0 is comprised of the following key blocks and functions:

- Three-axis MEMS rate gyroscope sensor with 16-bit ADCs and signal conditioning
- Three-axis MEMS accelerometer sensor with 16-bit ADCs and signal conditioning
- Digital Motion Processor (DMP) engine
- Primary I²C and SPI (MPU-6000 only) serial communications interfaces
- Auxiliary I²C serial interface for 3rd party magnetometer & other sensors
- Clocking
- Sensor Data Registers
- FIFO
- Interrupts
- Digital-Output Temperature Sensor
- Accelerometer Self-test
- Bias and LDO
- Charge Pump



7.7 Three-Axis MEMS Gyroscope with 16-bit ADCs and Signal Conditioning

The MPU-60X0 consists of three independent vibratory MEMS rate gyroscopes, which detect rotation about the X-, Y-, and Z- Axes. When the gyros are rotated about any of the sense axes, the Coriolis Effect causes a vibration that is detected by a capacitive pickoff. The resulting signal is amplified, demodulated, and filtered to produce a voltage that is proportional to the angular rate. This voltage is digitized using individual on-chip 16-bit Analog-to-Digital Converters (ADCs) to sample each axis. The full-scale range of the gyro sensors may be digitally programmed to ± 250 , ± 500 , ± 1000 , or ± 2000 degrees per second (dps). The ADC sample rate is programmable from 8,000 samples per second, down to 3.9 samples per second, and user-selectable low-pass filters enable a wide range of cut-off frequencies.

7.8 Three-Axis MEMS Accelerometer with 16-bit ADCs and Signal Conditioning

The MPU-60X0's 3-Axis accelerometer uses separate proof masses for each axis. Acceleration along a particular axis induces displacement on the corresponding proof mass, and capacitive sensors detect the displacement differentially. The MPU-60X0's architecture reduces the accelerometers' susceptibility to fabrication variations as well as to thermal drift. When the device is placed on a flat surface, it will measure 0g on the X- and Y-axes and +1g on the Z-axis. The accelerometers' scale factor is calibrated at the factory and is nominally independent of supply voltage. Each sensor has a dedicated sigma-delta ADC for providing digital outputs. The full scale range of the digital output can be adjusted to $\pm 2g$, $\pm 4g$, $\pm 8g$, or $\pm 16g$.

7.9 Digital Motion Processor

The embedded Digital Motion Processor (DMP) is located within the MPU-60X0 and offloads computation of motion processing algorithms from the host processor. The DMP acquires data from accelerometers, gyroscopes, and additional 3rd party sensors such as magnetometers, and processes the data. The resulting data can be read from the DMP's registers, or can be buffered in a FIFO. The DMP has access to one of the MPU's external pins, which can be used for generating interrupts.

The purpose of the DMP is to offload both timing requirements and processing power from the host processor. Typically, motion processing algorithms should be run at a high rate, often around 200Hz, in order to provide accurate results with low latency. This is required even if the application updates at a much lower rate; for example, a low power user interface may update as slowly as 5Hz, but the motion processing should still run at 200Hz. The DMP can be used as a tool in order to minimize power, simplify timing, simplify the software architecture, and save valuable MIPS on the host processor for use in the application.

7.10 Primary I²C and SPI Serial Communications Interfaces

The MPU-60X0 communicates to a system processor using either a SPI (MPU-6000 only) or an I²C serial interface. The MPU-60X0 always acts as a slave when communicating to the system processor. The LSB of the of the I²C slave address is set by pin 9 (AD0).

The logic levels for communications between the MPU-60X0 and its master are as follows:

- MPU-6000: The logic level for communications with the master is set by the voltage on VDD
- MPU-6050: The logic level for communications with the master is set by the voltage on VLOGIC

For further information regarding the logic levels of the MPU-6050, please refer to Section 10.

7.11 Auxiliary I²C Serial Interface

The MPU-60X0 has an auxiliary I²C bus for communicating to an off-chip 3-Axis digital output magnetometer or other sensors. This bus has two operating modes:

- I²C Master Mode: The MPU-60X0 acts as a master to any external sensors connected to the auxiliary I²C bus
- Pass-Through Mode: The MPU-60X0 directly connects the primary and auxiliary I²C buses together, allowing the system processor to directly communicate with any external sensors.

Auxiliary I²C Bus Modes of Operation:

- I²C Master Mode: Allows the MPU-60X0 to directly access the data registers of external digital sensors, such as a magnetometer. In this mode, the MPU-60X0 directly obtains data from auxiliary sensors, allowing the on-chip DMP to generate sensor fusion data without intervention from the system applications processor.

For example, In I²C Master mode, the MPU-60X0 can be configured to perform burst reads, returning the following data from a magnetometer:

- X magnetometer data (2 bytes)
- Y magnetometer data (2 bytes)
- Z magnetometer data (2 bytes)

The I²C Master can be configured to read up to 24 bytes from up to 4 auxiliary sensors. A fifth sensor can be configured to work single byte read/write mode.

- Pass-Through Mode: Allows an external system processor to act as master and directly communicate to the external sensors connected to the auxiliary I²C bus pins (AUX_DA and AUX_CL). In this mode, the auxiliary I²C bus control logic (3rd party sensor interface block) of the MPU-60X0 is disabled, and the auxiliary I²C pins AUX_DA and AUX_CL (Pins 6 and 7) are connected to the main I²C bus (Pins 23 and 24) through analog switches.

Pass-Through Mode is useful for configuring the external sensors, or for keeping the MPU-60X0 in a low-power mode when only the external sensors are used.

In Pass-Through Mode the system processor can still access MPU-60X0 data through the I²C interface.

Auxiliary I²C Bus IO Logic Levels

- MPU-6000: The logic level of the auxiliary I²C bus is VDD
- MPU-6050: The logic level of the auxiliary I²C bus can be programmed to be either VDD or VLOGIC

For further information regarding the MPU-6050's logic levels, please refer to Section 10.2.



7.12 Self-Test

Self-test allows for the testing of the mechanical and electrical portions of the accelerometers. The self-test for each measurement axis can be activated by controlling the bits of the ACCEL_CONFIG control register. When self-test is activated, the electronics cause the sensors to be actuated and produce an output signal.

The sensor reading is determined by the sum of the sensor output and the self-test response. The self-test response for each accelerometer axis is defined in the specification table (Section 6) to be nominally 0.5g.

For further information regarding the Accel control register, please refer to the MPU-60X0 Register Map and Register Descriptions document.

PRELIMINARY

7.13 MPU-60X0 Solution for 9-axis Sensor Fusion Using I²C Interface

In the figure below, the system processor is an I²C master to the MPU-60X0. In addition, the MPU-60X0 is an I²C master to the optional external compass sensor. The MPU-60X0 has limited capabilities as an I²C Master, and depends on the system processor to manage the initial configuration of any auxiliary sensors. The MPU-60X0 has an interface bypass multiplexer, which connects the system processor I²C bus pins 23 and 24 (SDA and SCL) directly to the auxiliary sensor I²C bus pins 6 and 7 (AUX_DA and AUX_CL).

Once the auxiliary sensors have been configured by the system processor, the interface bypass multiplexer should be disabled so that the MPU-60X0 auxiliary I²C master can take control of the sensor I²C bus and gather data from the auxiliary sensors.

For further information regarding I²C master control, please refer to Section 10.

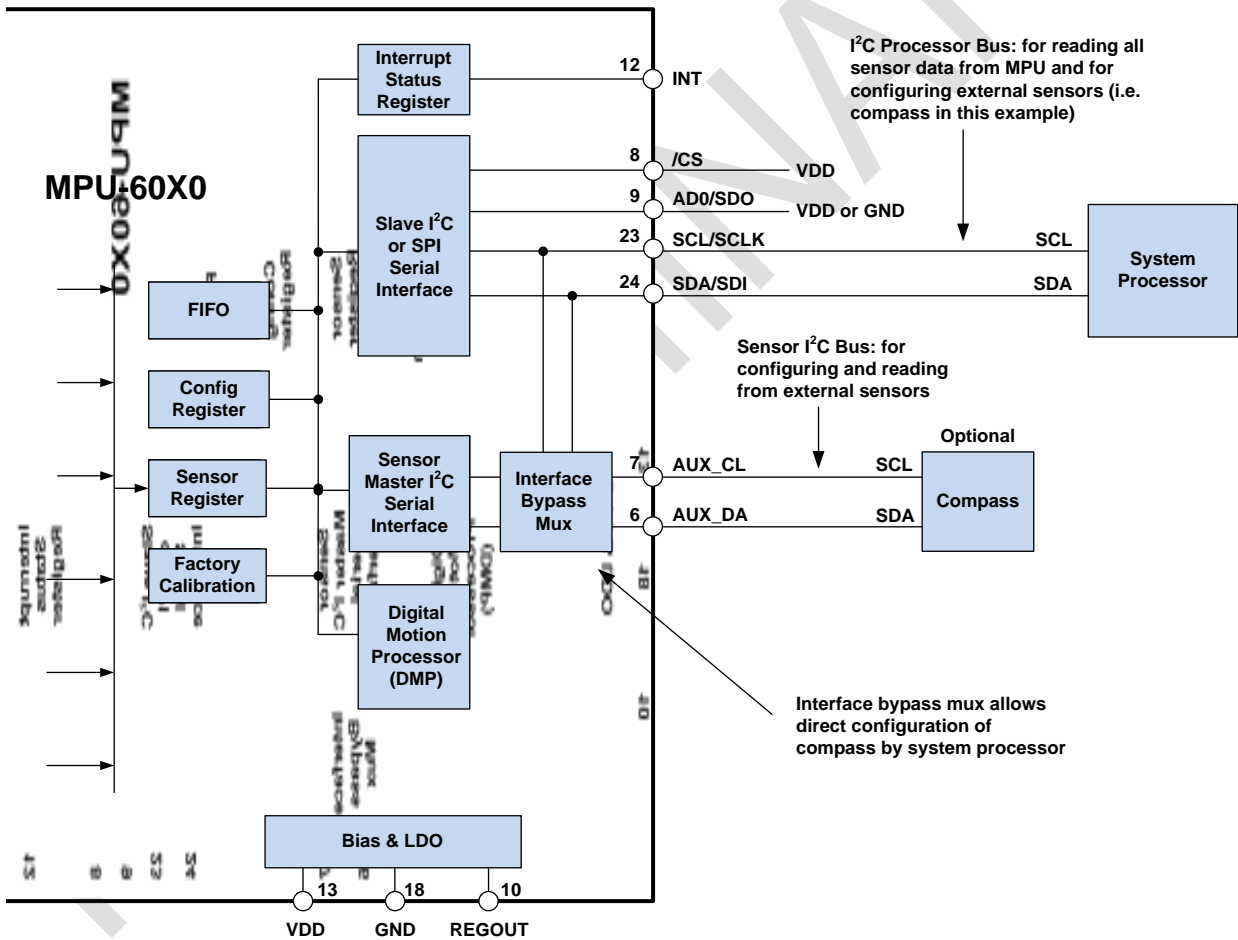

7.14 MPU-6000 Using SPI Interface

In the figure below, the system processor is an SPI master to the MPU-6000. Pins 8, 9, 23, and 24 are used to support the /CS, SDO, SCLK, and SDI signals for SPI communications. Because these SPI pins are shared with the I²C slave pins (9, 23 and 24), the system processor cannot access the auxiliary I²C bus through the interface bypass multiplexer, which connects the processor I²C interface pins to the sensor I²C interface pins.

Since the MPU-6000 has limited capabilities as an I²C Master, and depends on the system processor to manage the initial configuration of any auxiliary sensors, another method must be used for programming the sensors on the auxiliary sensor I²C bus pins 6 and 7 (AUX_DA and AUX_CL).

When using SPI communications between the MPU-6000 and the system processor, configuration of devices on the auxiliary I²C sensor bus can be achieved by using I²C Slaves 0-4 to perform read and write transactions on any device and register on the auxiliary I²C bus. The I²C Slave 4 interface can be used to perform only single byte read and write transactions.

Once the external sensors have been configured, the MPU-6000 can perform single or multi-byte reads using the sensor I²C bus. The read results from the Slave 0-3 controllers can be written to the FIFO buffer as well as to the external sensor registers.

For further information regarding the control of the MPU-60X0's auxiliary I²C interface, please refer to the MPU-60X0 Register Map and Register Descriptions document.

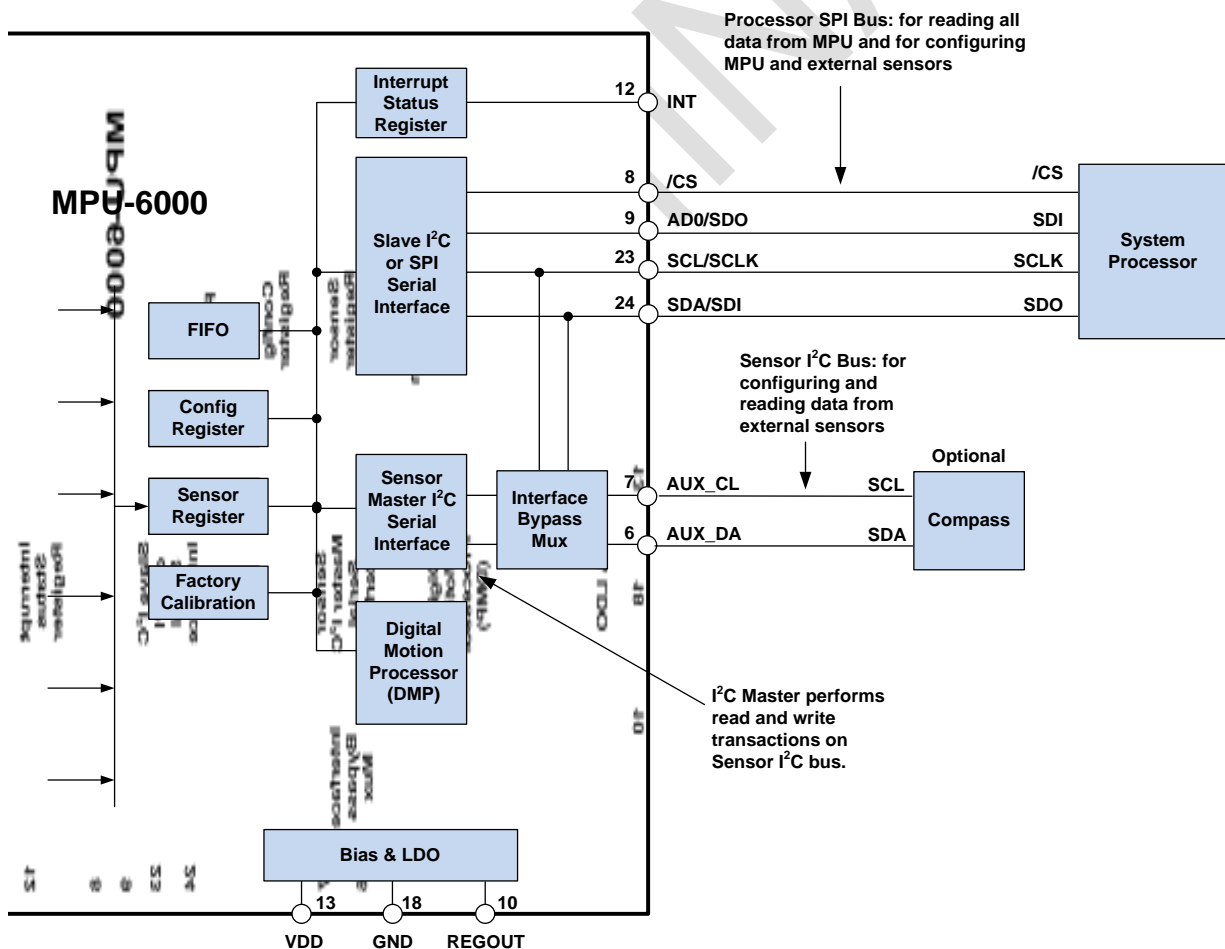

7.15 Internal Clock Generation

The MPU-60X0 has a flexible clocking scheme, allowing a variety of internal or external clock sources to be used for the internal synchronous circuitry. This synchronous circuitry includes the signal conditioning and ADCs, the DMP, and various control circuits and registers. An on-chip PLL provides flexibility in the allowable inputs for generating this clock.

Allowable internal sources for generating the internal clock are:

- An internal relaxation oscillator
- Any of the X, Y, or Z gyros (MEMS oscillators with a variation of $\pm 1\%$ over temperature)

Allowable external clocking sources are:

- 32.768kHz square wave
- 19.2MHz square wave

Selection of the source for generating the internal synchronous clock depends on the availability of external sources and the requirements for power consumption and clock accuracy. These requirements will most likely vary by mode of operation. For example, in one mode, where the biggest concern is power consumption, the user may wish to operate the Digital Motion Processor of the MPU-60X0 to process accelerometer data, while keeping the gyros off. In this case, the internal relaxation oscillator is a good clock choice. However, in another mode, where the gyros are active, selecting the gyros as the clock source provides for a more accurate clock source.

Clock accuracy is important, since timing errors directly affect the distance and angle calculations performed by the Digital Motion Processor (and by extension, by any processor).

There are also start-up conditions to consider. When the MPU-60X0 first starts up, the device uses its internal clock until programmed to operate from another source. This allows the user, for example, to wait for the MEMS oscillators to stabilize before they are selected as the clock source.

7.16 Sensor Data Registers

The sensor data registers contain the latest gyro, accelerometer, auxiliary sensor, and temperature measurement data. They are read-only registers, and are accessed via the serial interface. Data from these registers may be read anytime. However, the interrupt function may be used to determine when new data is available.

For a table of interrupt sources please refer to Section 8.

7.17 FIFO

The MPU-60X0 contains a 1024-byte FIFO register that is accessible via the Serial Interface. The FIFO configuration register determines which data is written into the FIFO. Possible choices include gyro data, accelerometer data, temperature readings, auxiliary sensor readings, and FSYNC input. A FIFO counter keeps track of how many bytes of valid data are contained in the FIFO. The FIFO register supports burst reads. The interrupt function may be used to determine when new data is available.

For further information regarding the FIFO, please refer to the MPU-60X0 Register Map and Register Descriptions document.

7.18 Interrupts

Interrupt functionality is configured via the Interrupt Configuration register. Items that are configurable include the INT pin configuration, the interrupt latching and clearing method, and triggers for the interrupt. Items that can trigger an interrupt are (1) Clock generator locked to new reference oscillator (used when switching clock sources); (2) new data is available to be read (from the FIFO and Data registers); (3) accelerometer event interrupts; and (4) the MPU-60X0 did not receive an acknowledge from an auxiliary sensor on the secondary I²C bus. The interrupt status can be read from the Interrupt Status register.

For further information regarding interrupts, please refer to the MPU-60X0 Register Map and Register Descriptions document.

For information regarding the MPU-60X0's accelerometer event interrupts, please refer to Section 8.

7.19 Digital-Output Temperature Sensor

An on-chip temperature sensor and ADC are used to measure the MPU-60X0 die temperature. The readings from the ADC can be read from the FIFO or the Sensor Data registers.

7.20 Bias and LDO

The bias and LDO section generates the internal supply and the reference voltages and currents required by the MPU-60X0. Its two inputs are an unregulated VDD of 2.1V to 3.6V and a VLOGIC logic reference supply voltage of 1.71V to VDD (MPU-6050 only). The LDO output is bypassed by a capacitor at REGOUT. For further details on the capacitor, please refer to the Bill of Materials for External Components (Section 7.3).

7.21 Charge Pump

An on-board charge pump generates the high voltage required for the MEMS oscillators. Its output is bypassed by a capacitor at CPOUT. For further details on the capacitor, please refer to the Bill of Materials for External Components (Section 7.3).



8 Programmable Interrupts

The MPU-60X0 has a programmable interrupt system which can generate an interrupt signal on the INT pin. Status flags indicate the source of an interrupt. Interrupt sources may be enabled and disabled individually.

Table of Interrupt Sources

| Interrupt Name | Module |
|---|-------------------------|
| Free Fall Detection | Free Fall |
| Motion Detection | Motion |
| Zero Motion Detection | Zero Motion |
| FIFO Overflow | FIFO |
| Data Ready | Sensor Registers |
| I ² C Master errors: Lost Arbitration, NACKs | I ² C Master |
| I ² C Slave 4 | I ² C Master |

For information regarding the interrupt enable/disable registers and flag registers, please refer to the MPU-6000/MPU-6050 Register Map and Register Descriptions document. Some interrupt sources are explained below.

8.1 Free Fall, Motion, and Zero Motion Signal Paths

The diagram below shows the signal path for the gyroscope and accelerometer sensors. Note that each digital low pass filter (DLPF) is configured identically, as is each sample rate divider and digital high pass filter (DHPF).

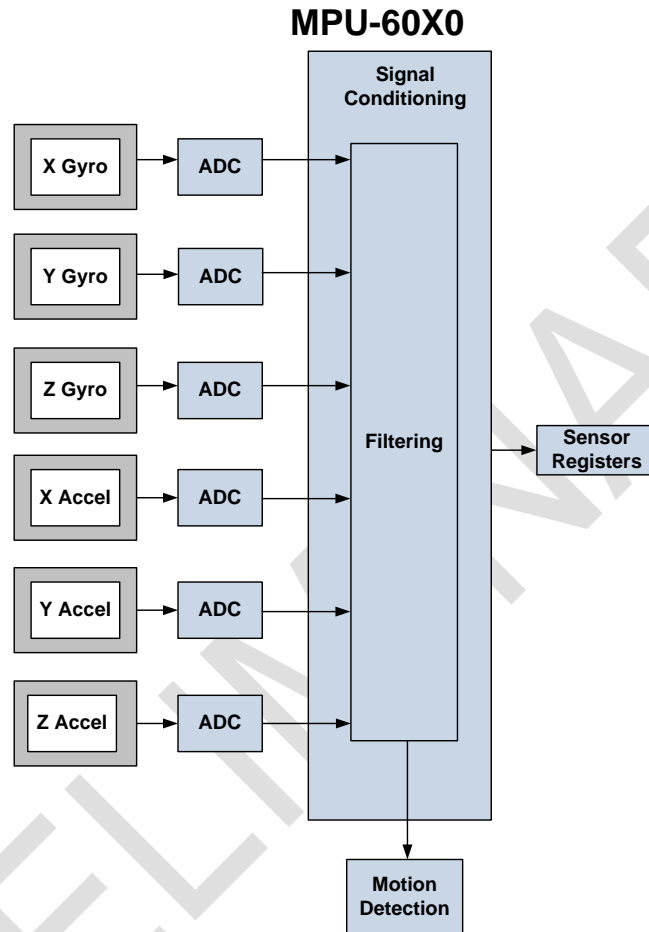

8.2 Free Fall Interrupt

Free fall is detected by checking if the accelerometer measurements from all 3 axes have an absolute value below a user-programmable threshold (acceleration threshold). For each sample where this condition is true (a qualifying sample), a counter is incremented. For each sample where this condition is false (a non-qualifying sample), the counter is decremented. Once the counter reaches a user-programmable threshold (the counter threshold), the Free Fall interrupt is triggered and a flag is set. The flag is cleared once the counter has decremented to zero. The counter does not increment above the counter threshold or decrement below zero.

The user is given several configuration parameters to fine tune Free Fall detection. Both, the acceleration threshold and counter threshold are user configurable. The FF_THR register allows the user to set a threshold in 2 mg increments. The FF_DUR register allows the user to set duration in 1 ms increments.

The decrement rate for non-qualifying samples is also configurable. The MOT_DETECT_CTRL register allows the user to specify whether a non-qualifying sample makes the counter reset to zero, or decrement in steps of 1, 2, or 4.

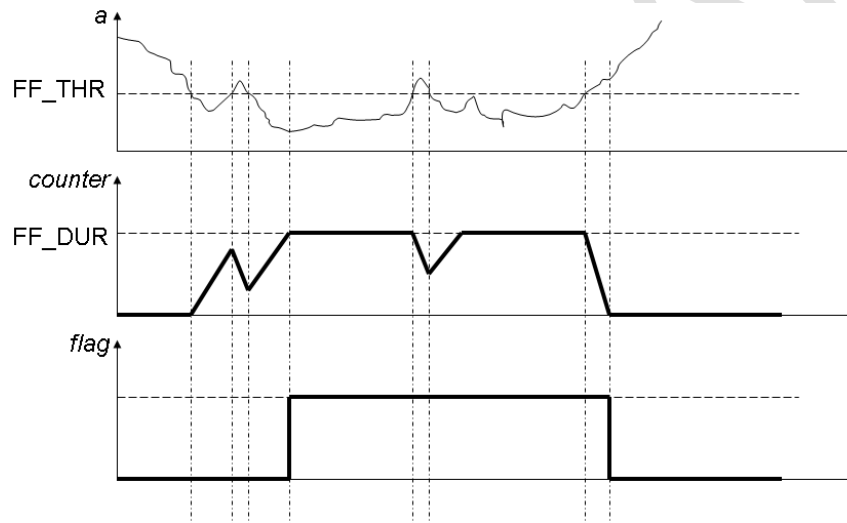

The figure above shows a simplified example with just one axis. An example acceleration input signal (simplified to only show one axis), qualifying sample counter, and Free Fall flag are shown.

8.3 Motion Interrupt

The MPU-60X0 provides Motion detection capability with similar functionality to Free Fall detection. Accelerometer measurements are passed through a configurable digital high pass filter (DHPF) in order to eliminate bias due to gravity. A qualifying motion sample is one where the high passed sample from any axis has an absolute value exceeding a user-programmable threshold. A counter increments for each qualifying sample, and decrements for each non-qualifying sample. Once the counter reaches a user-programmable counter threshold, a motion interrupt is triggered. The axis and polarity which caused the interrupt to be triggered is flagged in the MOT_DETECT_STATUS register.

Like Free Fall detection, Motion detection has a configurable acceleration threshold **MOT_THR** specified in 2 mg increments. The counter threshold **MOT_DUR** is specified in 1 ms increments. The decrement rate has the same options as Free Fall detection, and is specified in the **MOT_DETECT_CTRL** register.



8.4 Zero Motion Interrupt

The Zero Motion detection capability uses the digital high pass filter (DHPF) and a similar threshold scheme to that of Free Fall detection. Each axis of the high passed accelerometer measurement must have an absolute value less than a threshold specified in the ZRMOT_THR register, which can be increased in 2mg increments. Each time a motion sample meets this condition, a counter increments. When this counter reaches a threshold specified in ZRMOT_DUR, an interrupt is generated.

Unlike Free Fall or Motion detection, Zero Motion detection triggers an interrupt both when Zero Motion is first detected and when Zero Motion is no longer detected. While Free Fall and Motion are indicated with a flag which clears after being read, reading the state of the Zero Motion detected from the MOT_DETECT_STATUS register does not clear its status.

PRELIMINARY

9 Digital Interface

9.1 I²C and SPI (MPU-6000 only) Serial Interfaces

The internal registers and memory of the MPU-6000/MPU-6050 can be accessed using either I²C at 400 kHz or SPI at 1MHz (MPU-6000 only). SPI operates in four-wire mode.

Serial Interface

| Pin Number | MPU-6000 | MPU-6050 | Pin Name | Pin Description |
|------------|----------|----------|------------|--|
| 8 | Y | | /CS | SPI chip select (0=SPI enable) |
| 8 | | Y | VLOGIC | Digital I/O supply voltage. VLOGIC must be \leq VDD at all times. |
| 9 | Y | | AD0 / SDO | I ² C Slave Address LSB (AD0); SPI serial data output (SDO) |
| 9 | | Y | AD0 | I ² C Slave Address LSB |
| 23 | Y | | SCL / SCLK | I ² C serial clock (SCL); SPI serial clock (SCLK) |
| 23 | | Y | SCL | I ² C serial clock |
| 24 | Y | | SDA / SDI | I ² C serial data (SDA); SPI serial data input (SDI) |
| 24 | | Y | SDA | I ² C serial data |

Note:

To prevent switching into I²C mode when using SPI (MPU-6000), the I²C interface should be disabled by setting the *I2C_IF_DIS* configuration bit. Setting this bit should be performed immediately after waiting for the time specified by the "Start-Up Time for Register Read/Write" in Section 6.3.

For further information regarding the *I2C_IF_DIS* bit, please refer to the MPU-60X0 Register Map and Register Descriptions document.

9.2 I²C Interface

I²C is a two-wire interface comprised of the signals serial data (SDA) and serial clock (SCL). In general, the lines are open-drain and bi-directional. In a generalized I²C interface implementation, attached devices can be a master or a slave. The master device puts the slave address on the bus, and the slave device with the matching address acknowledges the master.

The MPU-60X0 always operates as a slave device when communicating to the system processor, which thus acts as the master. SDA and SCL lines typically need pull-up resistors to VDD. The maximum bus speed is 400 kHz.

The slave address of the MPU-60X0 is b110100X which is 7 bits long. The LSB bit of the 7 bit address is determined by the logic level on pin AD0. This allows two MPU-60X0s to be connected to the same I²C bus. When used in this configuration, the address of the one of the devices should be b1101000 (pin AD0 is logic low) and the address of the other should be b1101001 (pin AD0 is logic high).

9.3 I²C Communications Protocol

START (S) and STOP (P) Conditions

Communication on the I²C bus starts when the master puts the START condition (S) on the bus, which is defined as a HIGH-to-LOW transition of the SDA line while SCL line is HIGH (see figure below). The bus is considered to be busy until the master puts a STOP condition (P) on the bus, which is defined as a LOW to HIGH transition on the SDA line while SCL is HIGH (see figure below).

Additionally, the bus remains busy if a repeated START (Sr) is generated instead of a STOP condition.

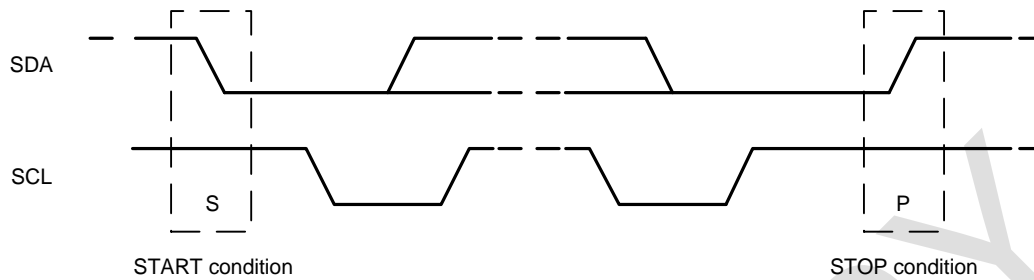

START and STOP Conditions

Data Format / Acknowledge

I²C data bytes are defined to be 8-bits long. There is no restriction to the number of bytes transmitted per data transfer. Each byte transferred must be followed by an acknowledge (ACK) signal. The clock for the acknowledge signal is generated by the master, while the receiver generates the actual acknowledge signal by pulling down SDA and holding it low during the HIGH portion of the acknowledge clock pulse.

If a slave is busy and cannot transmit or receive another byte of data until some other task has been performed, it can hold SCL LOW, thus forcing the master into a wait state. Normal data transfer resumes when the slave is ready, and releases the clock line (refer to the following figure).

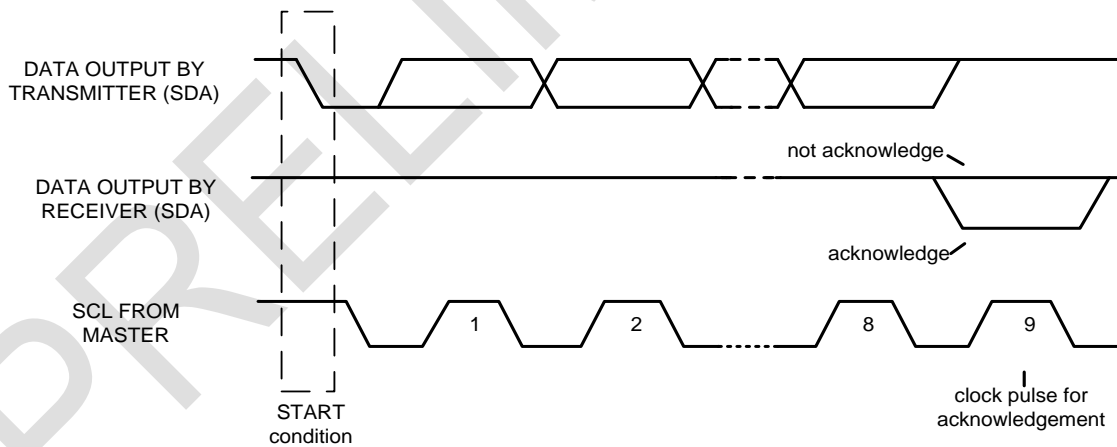

Acknowledge on the I²C Bus

Communications

After beginning communications with the START condition (S), the master sends a 7-bit slave address followed by an 8th bit, the read/write bit. The read/write bit indicates whether the master is receiving data from or is writing to the slave device. Then, the master releases the SDA line and waits for the acknowledge signal (ACK) from the slave device. Each byte transferred must be followed by an acknowledge bit. To acknowledge, the slave device pulls the SDA line LOW and keeps it LOW for the high period of the SCL line. Data transmission is always terminated by the master with a STOP condition (P), thus freeing the communications line. However, the master can generate a repeated START condition (Sr), and address another slave without first generating a STOP condition (P). A LOW to HIGH transition on the SDA line while SCL is HIGH defines the stop condition. All SDA changes should take place when SCL is low, with the exception of start and stop conditions.

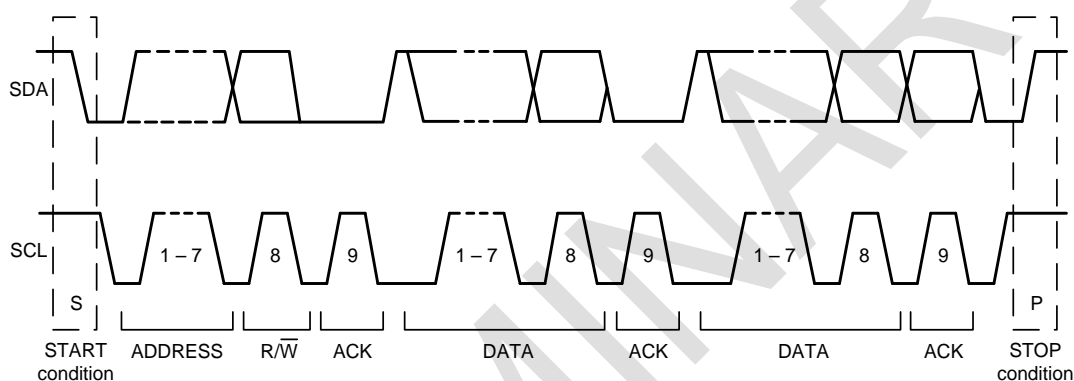

Complete I²C Data Transfer

To write the internal MPU-60X0 registers, the master transmits the start condition (S), followed by the I²C address and the write bit (0). At the 9th clock cycle (when the clock is high), the MPU-60X0 acknowledges the transfer. Then the master puts the register address (RA) on the bus. After the MPU-60X0 acknowledges the reception of the register address, the master puts the register data onto the bus. This is followed by the ACK signal, and data transfer may be concluded by the stop condition (P). To write multiple bytes after the last ACK signal, the master can continue outputting data rather than transmitting a stop signal. In this case, the MPU-60X0 automatically increments the register address and loads the data to the appropriate register. The following figures show single and two-byte write sequences.

Single-Byte Write Sequence

| | | | | | | | | |
|--------|---|------|-----|----|-----|------|-----|---|
| Master | S | AD+W | | RA | | DATA | | P |
| Slave | | | ACK | | ACK | | ACK | |

Burst Write Sequence

| | | | | | | | | | | |
|--------|---|------|-----|----|-----|------|-----|------|-----|---|
| Master | S | AD+W | | RA | | DATA | | DATA | | P |
| Slave | | | ACK | | ACK | | ACK | | ACK | |

To read the internal MPU-60X0 registers, the master sends a start condition, followed by the I²C address and a write bit, and then the register address that is going to be read. Upon receiving the ACK signal from the MPU-60X0, the master transmits a start signal followed by the slave address and read bit. As a result, the MPU-60X0 sends an ACK signal and the data. The communication ends with a not acknowledge (NACK) signal and a stop bit from master. The NACK condition is defined such that the SDA line remains high at the 9th clock cycle. The following figures show single and two-byte read sequences.

Single-Byte Read Sequence

| | | | | | | | | | | | |
|--------|---|------|-----|----|-----|---|------|-----|------|------|---|
| Master | S | AD+W | | RA | | S | AD+R | | | NACK | P |
| Slave | | | ACK | | ACK | | | ACK | DATA | | |

Burst Read Sequence

| | | | | | | | | | | | | | |
|--------|---|------|-----|----|-----|---|------|-----|------|-----|------|------|---|
| Master | S | AD+W | | RA | | S | AD+R | | | ACK | | NACK | P |
| Slave | | | ACK | | ACK | | | ACK | DATA | | DATA | | |

9.4 I²C Terms

| Signal | Description |
|--------|--|
| S | Start Condition: SDA goes from high to low while SCL is high |
| AD | Slave I ² C address |
| W | Write bit (0) |
| R | Read bit (1) |
| ACK | Acknowledge: SDA line is low while the SCL line is high at the 9 th clock cycle |
| NACK | Not-Acknowledge: SDA line stays high at the 9 th clock cycle |
| RA | MPU-60X0 internal register address |
| DATA | Transmit or received data |
| P | Stop condition: SDA going from low to high while SCL is high |

9.5 SPI Interface (MPU-6000 only)

SPI is a 4-wire synchronous serial interface that uses two control lines and two data lines. The MPU-6000 always operates as a Slave device during standard Master-Slave SPI operation.

With respect to the Master, the Serial Clock output (SCLK), the Serial Data Output (SDO) and the Serial Data Input (SDI) are shared among the Slave devices. Each SPI slave device requires its own Chip Select (/CS) line from the master.

/CS goes low (active) at the start of transmission and goes back high (inactive) at the end. Only one /CS line is active at a time, ensuring that only one slave is selected at any given time. The /CS lines of the non-selected slave devices are held high, causing their SDO lines to remain in a high-impedance (high-z) state so that they do not interfere with any active devices.

SPI Operational Features

1. Data is delivered MSB first and LSB last
2. Data is latched on the rising edge of SCLK
3. Data should be transitioned on the falling edge of SCLK
4. The maximum frequency of SCLK is 1MHz
5. SPI read and write operations are completed in 16 or more clock cycles (two or more bytes). The first byte contains the SPI Address, and the following byte(s) contain(s) the SPI data. The first bit of the first byte contains the Read/Write bit and indicates the Read (1) or Write (0) operation. The following 7 bits contain the Register Address. In cases of multiple-byte Read/Writes, data is two or more bytes:

SPI Address format

| MSB | | | | | | | LSB |
|-----|----|----|----|----|----|----|-----|
| R/W | A6 | A5 | A4 | A3 | A2 | A1 | A0 |

SPI Data format

| MSB | | | | | | | LSB |
|-----|----|----|----|----|----|----|-----|
| D7 | D6 | D5 | D4 | D3 | D2 | D1 | D0 |

6. Supports Single or Burst Read/Writes.

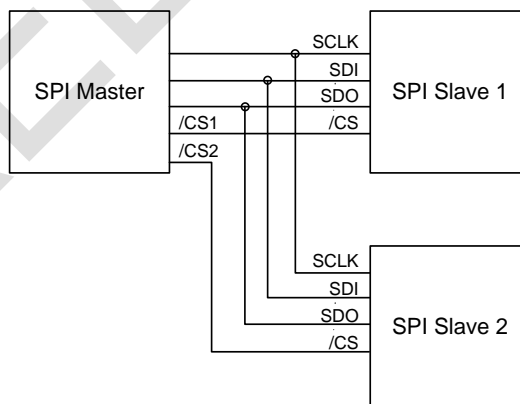

Typical SPI Master / Slave Configuration



10 Serial Interface Considerations (MPU-6050)

10.1 MPU-6050 Supported Interfaces

The MPU-6050 supports I²C communications on both its primary (microprocessor) serial interface and its auxiliary interface.

10.2 Logic Levels

The MPU-6050's I/O logic levels are set to be either VDD or VLOGIC, as shown in the table below.

I/O Logic Levels vs. AUX_VDDIO

| <i>AUX_VDDIO</i> | MICROPROCESSOR LOGIC LEVELS (Pins: SDA, SCL, AD0, CLKIN, INT) | AUXILLARY LOGIC LEVELS (Pins: AUX_DA, AUX_CL) |
|------------------|---|---|
| 0 | VLOGIC | VLOGIC |
| 1 | VLOGIC | VDD |

Note: The power-on-reset value for *AUX_VDDIO* is 0.

VLOGIC may be set to be equal to VDD or to another voltage. However, VLOGIC must be \leq VDD at all times. When *AUX_VDDIO* is set to 0 (its power-on-reset value), VLOGIC is the power supply voltage for both the microprocessor system bus and the auxiliary I²C bus, as shown in the figure of Section 10.3. When *AUX_VDDIO* is set to 1, VLOGIC is the power supply voltage for the microprocessor system bus and VDD is the supply for the auxiliary I²C bus, as shown in the figure of Section 10.4.

10.3 Logic Levels Diagram for AUX_VDDIO = 0

The figure below depicts a sample circuit with a third party magnetometer attached to the auxiliary I²C bus. It shows logic levels and voltage connections for AUX_VDDIO = 0. Note: Actual configuration will depend on the auxiliary sensors used.

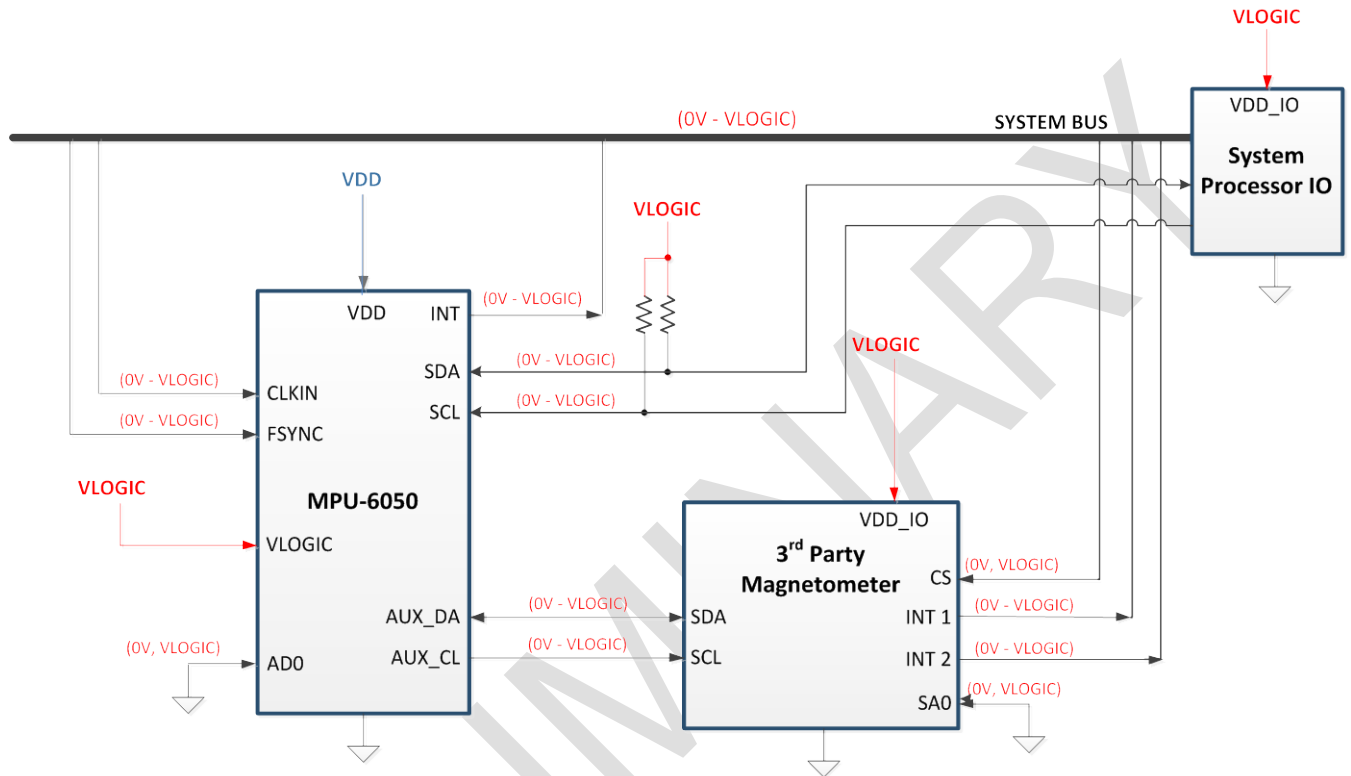

I/O Levels and Connections for AUX_VDDIO = 0

Notes:

1. AUX_VDDIO determines the IO voltage levels of AUX_DA and AUX_CL (0 = set output levels relative to VLOGIC)
2. CLKOUT is referenced to VDD.
3. All other MPU-6050 logic IOs are referenced to VLOGIC.

10.4 Logic Levels Diagram for $AUX_VDDIO = 1$

The figure below depicts a sample circuit with a 3rd party magnetometer attached to the auxiliary I²C bus. It shows logic levels and voltage connections for $AUX_VDDIO = 1$. This configuration is useful when the auxiliary sensor has only one supply for logic and power. Note: Actual configuration will depend on the auxiliary sensors used.

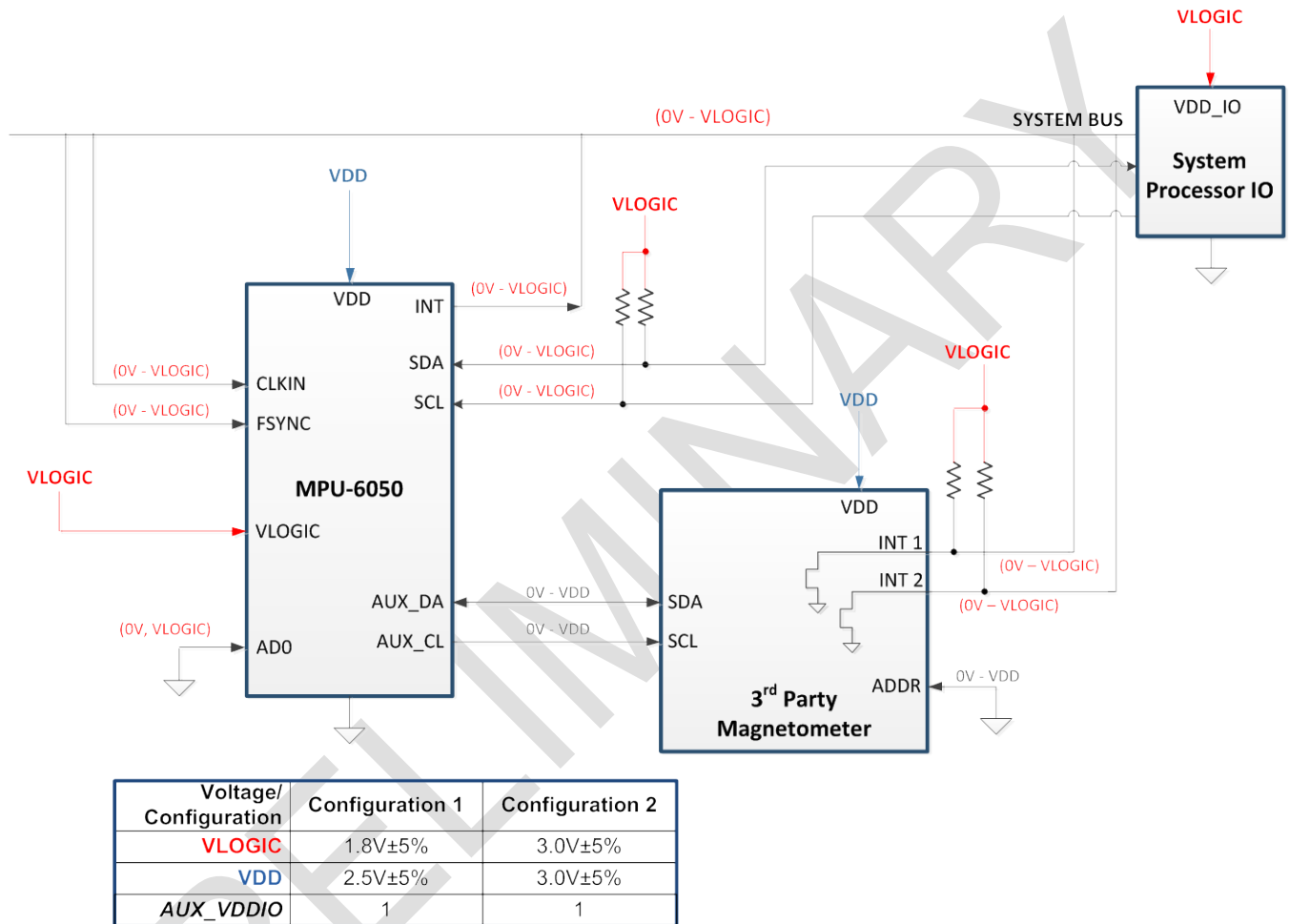
I/O Levels and Connections for Two Example Power Configurations ($AUX_VDDIO = 1$)
Notes:

1. AUX_VDDIO determines the IO voltage levels of AUX_DA and AUX_CL . $AUX_VDDIO = 1$ sets output levels relative to VDD .
2. 3rd-party auxiliary device logic levels are referenced to VDD . Setting $INT1$ and $INT2$ to open drain configuration provides voltage compatibility when $VDD \neq VLOGIC$. When $VDD = VLOGIC$, $INT1$ and $INT2$ may be set to push-pull outputs, and external pull-up resistors are not needed.
3. $CLKOUT$ is referenced to VDD .
4. All other MPU-6050 logic IOs are referenced to $VLOGIC$.

11 Assembly

This section provides general guidelines for assembling InvenSense Micro Electro-Mechanical Systems (MEMS) gyros packaged in Quad Flat No leads package (QFN) surface mount integrated circuits.

11.1 Orientation of Axes

The diagram below shows the orientation of the axes of sensitivity and the polarity of rotation. Note the pin 1 identifier (•) in the figure.

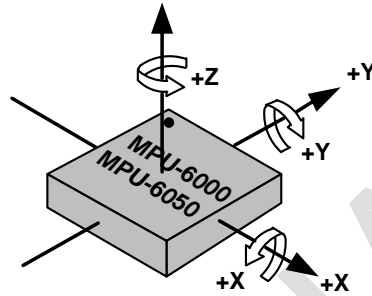

Orientation of Axes of Sensitivity and Polarity of Rotation

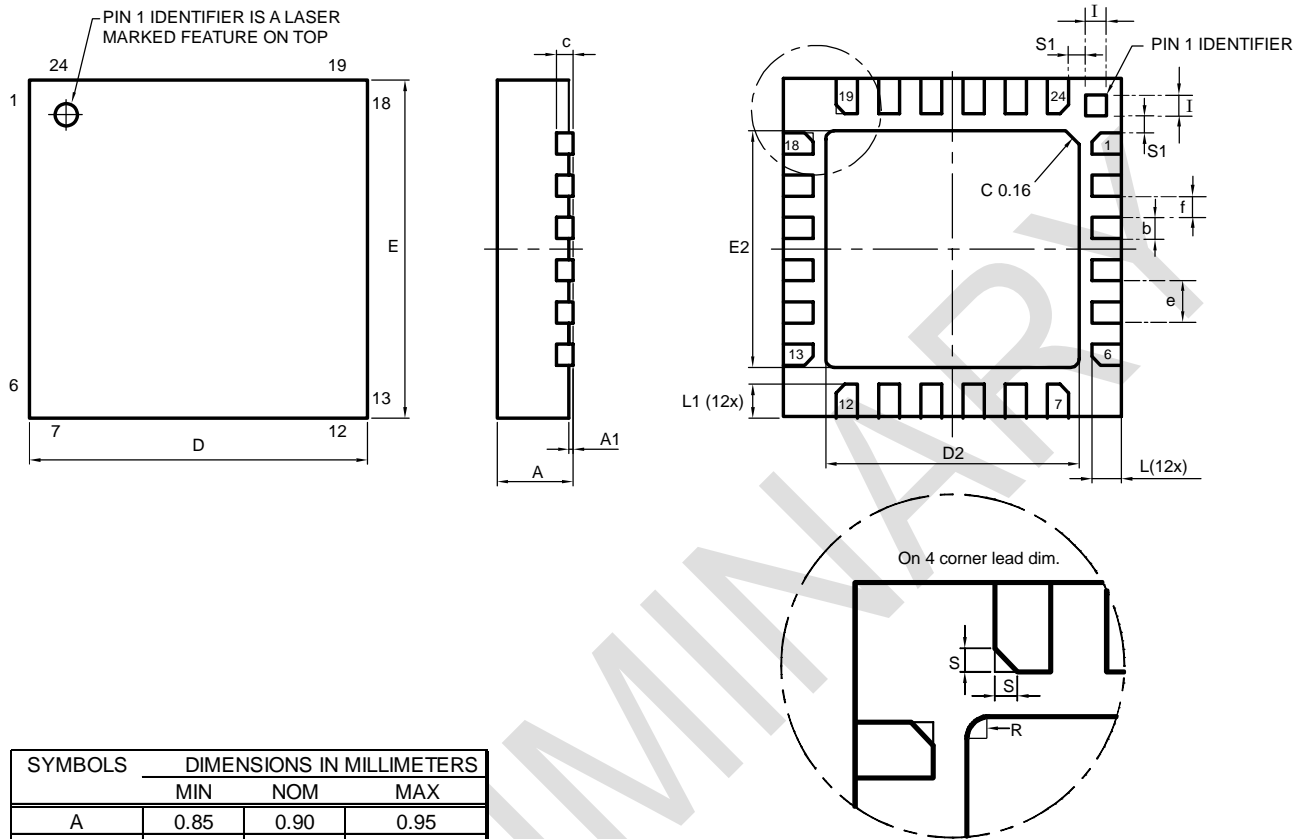
11.2 Package Dimensions

| SYMBOLS | DIMENSIONS IN MILLIMETERS | | |
|---------|---------------------------|-----------|------|
| | MIN | NOM | MAX |
| A | 0.85 | 0.90 | 0.95 |
| A1 | 0.00 | 0.02 | 0.05 |
| b | 0.18 | 0.25 | 0.30 |
| c | --- | 0.20 REF. | --- |
| D | 3.90 | 4.00 | 4.10 |
| D2 | 2.95 | 3.00 | 3.05 |
| E | 3.90 | 4.00 | 4.10 |
| E2 | 2.75 | 2.80 | 2.85 |
| e | --- | 0.50 | --- |
| f (e-b) | 0.20 | 0.25 | 0.32 |
| L | 0.30 | 0.35 | 0.40 |
| L1 | 0.35 | 0.40 | 0.45 |
| l | 0.20 | 0.25 | 0.30 |
| R | 0.05 | --- | 0.10 |
| s | 0.05 | --- | 0.15 |
| S1 | 0.15 | 0.20 | 0.25 |

11.3 PCB Design Guidelines:

The Pad Diagram using a JEDEC type extension with solder rising on the outer edge is shown below. The Pad Dimensions Table shows pad sizing (mean dimensions) recommended for the MPU-60X0 product.

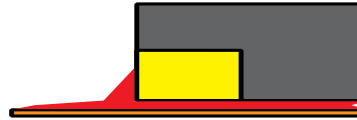

JEDEC type extension with solder rising on outer edge

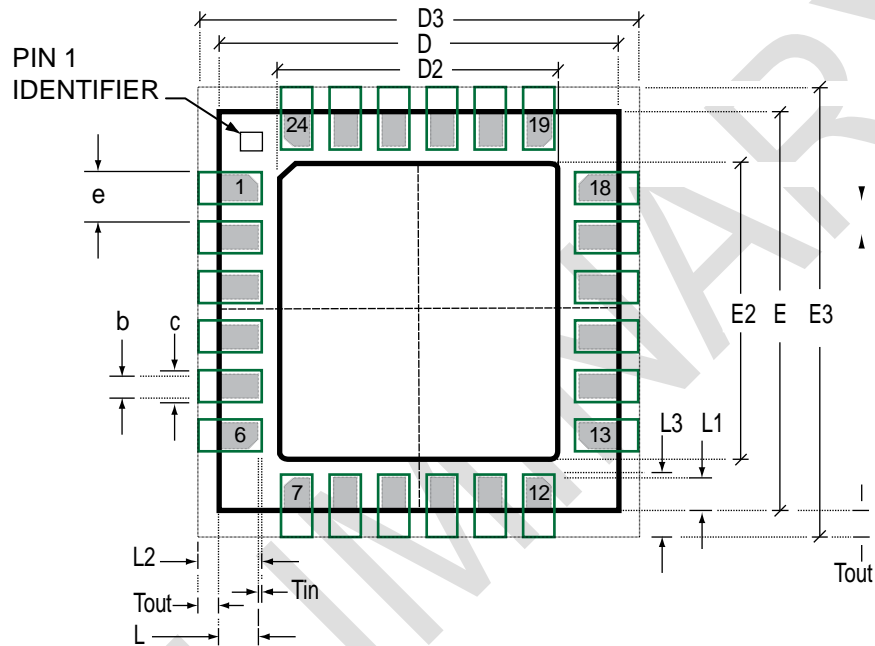
PCB Lay-out Diagram

| SYMBOLS | DIMENSIONS IN MILLIMETERS | NOM |
|---|---------------------------|------|
| Nominal Package I/O Pad Dimensions | | |
| e | Pad Pitch | 0.50 |
| b | Pad Width | 0.25 |
| L | Pad Length | 0.35 |
| L1 | Pad Length | 0.40 |
| D | Package Width | 4.00 |
| E | Package Length | 4.00 |
| D2 | Exposed Pad Width | 3.00 |
| E2 | Exposed Pad Length | 2.80 |
| I/O Land Design Dimensions (Guidelines) | | |
| D3 | I/O Pad Extent Width | 4.80 |
| E3 | I/O Pad Extent Length | 4.80 |
| c | Land Width | 0.35 |
| Tout | Outward Extension | 0.40 |
| Tin | Inward Extension | 0.05 |
| L2 | Land Length | 0.80 |
| L3 | Land Length | 0.85 |

PCB Dimensions Table (for PCB Lay-out Diagram)

11.4 Assembly Precautions

11.4.1 Gyroscope Surface Mount Guidelines

InvenSense MEMS Gyros sense rate of rotation. In addition, gyroscopes sense mechanical stress coming from the printed circuit board (PCB). This PCB stress can be minimized by adhering to certain design rules:

When using MEMS gyroscope components in plastic packages, PCB mounting and assembly can cause package stress. This package stress in turn can affect the output offset and its value over a wide range of temperatures. This stress is caused by the mismatch between the Coefficient of Linear Thermal Expansion (CTE) of the package material and the PCB. Care must be taken to avoid package stress due to mounting.

Traces connected to pads should be as symmetric as possible. Maximizing symmetry and balance for pad connection will help component self alignment and will lead to better control of solder paste reduction after reflow.

Any material used in the surface mount assembly process of the MEMS gyroscope should be free of restricted RoHS elements or compounds. Pb-free solders should be used for assembly.

11.4.2 Exposed Die Pad Precautions

The MPU-60X0 has very low active and standby current consumption. The exposed die pad is not required for heat sinking, and should not be soldered to the PCB. Failure to adhere to this rule can induce performance changes due to package thermo-mechanical stress. There is no electrical connection between the pad and the CMOS.

11.4.3 Trace Routing

Routing traces or vias under the gyro package such that they run under the exposed die pad is prohibited. Routed active signals may harmonically couple with the gyro MEMS devices, compromising gyro response. These devices are designed with the drive frequencies as follows: $X = 33 \pm 3\text{KHz}$, $Y = 30 \pm 3\text{KHz}$, and $Z = 27 \pm 3\text{KHz}$. To avoid harmonic coupling don't route active signals in non-shielded signal planes directly below, or above the gyro package. Note: For best performance, design a ground plane under the e-pad to reduce PCB signal noise from the board on which the gyro device is mounted. If the gyro device is stacked under an adjacent PCB board, design a ground plane directly above the gyro device to shield active signals from the adjacent PCB board.

11.4.4 Component Placement

Do not place large insertion components such as keyboard or similar buttons, connectors, or shielding boxes at a distance of less than 6 mm from the MEMS gyro. Maintain generally accepted industry design practices for component placement near the MPU-60X0 to prevent noise coupling and thermo-mechanical stress.

11.4.5 PCB Mounting and Cross-Axis Sensitivity

Orientation errors of the gyroscope and accelerometer mounted to the printed circuit board can cause cross-axis sensitivity in which one gyro or accel responds to rotation or acceleration about another axis, respectively. For example, the X-axis gyroscope may respond to rotation about the Y or Z axes. The orientation mounting errors are illustrated in the figure below.

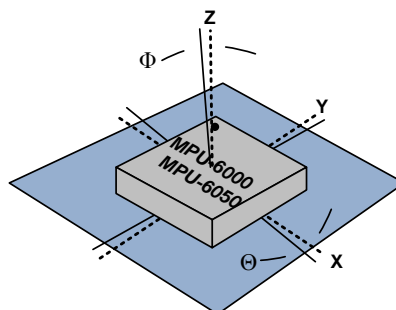

Package Gyro & Accel Axes (- - -) Relative to PCB Axes (———) with Orientation Errors (Θ and Φ)

The table below shows the cross-axis sensitivity as a percentage of the gyroscope or accelerometer's sensitivity for a given orientation error, respectively.

| Orientation Error (θ or Φ) | Cross-Axis Sensitivity ($\sin\theta$ or $\sin\Phi$) |
|---|--|
| 0° | 0% |
| 0.5° | 0.87% |
| 1° | 1.75% |

The specifications for cross-axis sensitivity in Section 6.1 and Section 6.2 include the effect of the die orientation error with respect to the package.

11.4.6 MEMS Handling Instructions

MEMS (Micro Electro-Mechanical Systems) are a time-proven, robust technology used in hundreds of millions of consumer, automotive and industrial products. MEMS devices consist of microscopic moving mechanical structures. They differ from conventional IC products, even though they can be found in similar packages. Therefore, MEMS devices require different handling precautions than conventional ICs prior to mounting onto printed circuit boards (PCBs).

The MPU-60X0 has been qualified to a shock tolerance of 10,000g. InvenSense packages its gyroscopes as it deems proper for protection against normal handling and shipping. It recommends the following handling precautions to prevent potential damage.

- Do not drop individually packaged gyroscopes, or trays of gyroscopes onto hard surfaces. Components placed in trays could be subject to *g*-forces in excess of 10,000g if dropped.
- Printed circuit boards that incorporate mounted gyroscopes should not be separated by manually snapping apart. This could also create *g*-forces in excess of 10,000g.

11.4.7 ESD Considerations

Establish and use ESD-safe handling precautions when unpacking and handling ESD-sensitive devices.

- Store ESD sensitive devices in ESD safe containers until ready for use. The Tape-and-Reel moisture-sealed bag is an ESD approved barrier. The best practice is to keep the units in the original moisture sealed bags until ready for assembly.

Restrict all device handling to ESD protected work areas that measure less than 200V static charge. Ensure that all workstations and personnel are properly grounded to prevent ESD.

11.4.8 Reflow Specification

Qualification Reflow: The MPU-60X0 was qualified in accordance with IPC/JEDEC J-STD-020D.01. This standard classifies proper packaging, storage and handling in order to avoid subsequent thermal and mechanical damage during the solder reflow attachment phase of assembly. The classification specifies a sequence consisting of a bake cycle, a moisture soak cycle in a temperature humidity oven, followed by three solder reflow cycles and functional testing for qualification. All temperatures refer to the topside of the QFN package, as measured on the package body surface. The peak solder reflow classification temperature requirement is $(260 \pm 5/-0^\circ\text{C})$ for lead-free soldering of components measuring less than 1.6 mm in thickness.

Production Reflow: Check the recommendations of your solder manufacturer. For optimum results, production solder reflow processes should reduce exposure to high temperatures, and use lower ramp-up and ramp-down rates than those used in the component qualification profile shown for reference below.

Production reflow should never exceed the maximum constraints listed in the table and shown in the figure below that were used for the qualification profile, as these represent the maximum tolerable ratings for the device.

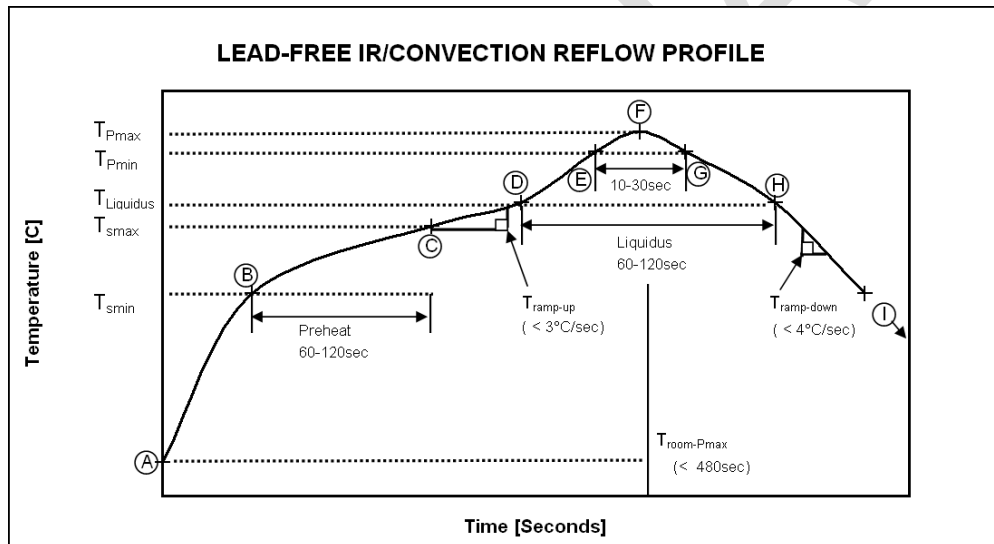

Approved IR/Convection Solder Reflow Curve

Temperature Set Points for IR / Convection Reflow Corresponding to Figure Above

| Step | Setting | CONSTRAINTS | | |
|------|---------------------------|-------------|---------------------|--------------------------------|
| | | Temp (°C) | Time (sec) | Rate (°C/sec) |
| A | T_{room} | 25 | | |
| B | T_{Smin} | 150 | | |
| C | T_{Smax} | 200 | $60 < t_{BC} < 120$ | |
| D | $T_{Liquidus}$ | 217 | | $r(T_{Liquidus}-T_{Pmax}) < 3$ |
| E | T_{Pmin} [255°C, 260°C] | 255 | | $r(T_{Liquidus}-T_{Pmax}) < 3$ |
| F | T_{Pmax} [260°C, 265°C] | 260 | $t_{AF} < 480$ | $r(T_{Liquidus}-T_{Pmax}) < 3$ |
| G | T_{Pmin} [255°C, 260°C] | 255 | $10 < t_{EG} < 30$ | $r(T_{Pmax}-T_{Liquidus}) < 4$ |
| H | $T_{Liquidus}$ | 217 | $60 < t_{DH} < 120$ | |
| I | T_{room} | 25 | | |



Note: For users T_{Pmax} must not exceed the Classification temperature (260°C).

For suppliers T_{Pmax} must equal or exceed the classification temperature.

PRELIMINARY

11.5 Storage Specifications

The storage specification of the MPU-60X0 conforms to IPC/JEDEC J-STD-020D.01 Moisture Sensitivity Level (MSL) 3.

| | |
|--|---|
| Calculated shelf-life in moisture-sealed bag | 12 months -- Storage conditions: <40°C and <90% RH |
| After opening moisture-sealed bag | 168 hours -- Storage conditions: ambient ≤30°C at 60%RH |

11.6 Package Marking Specification

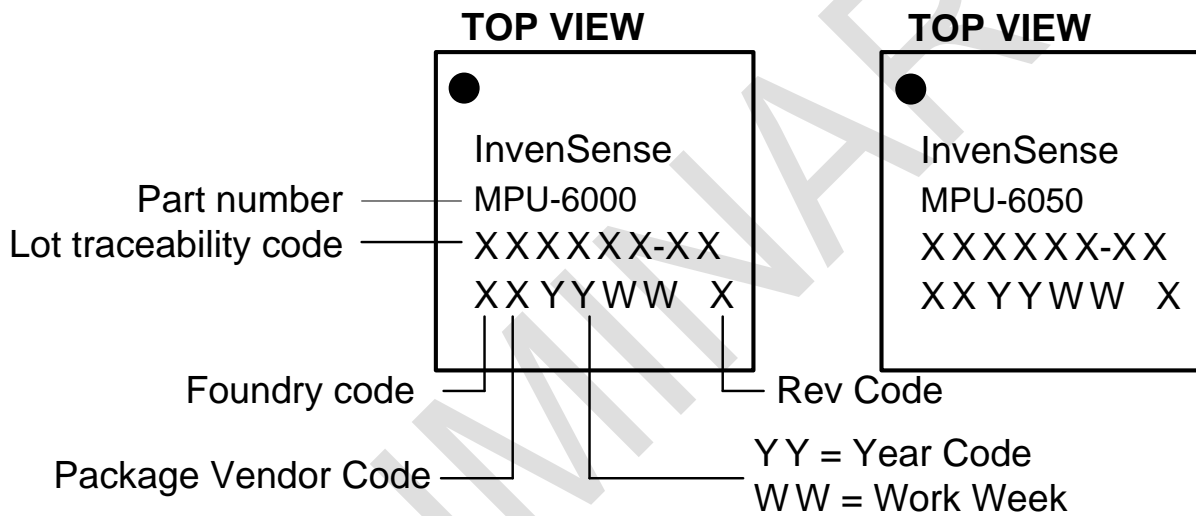

Package Marking Specification

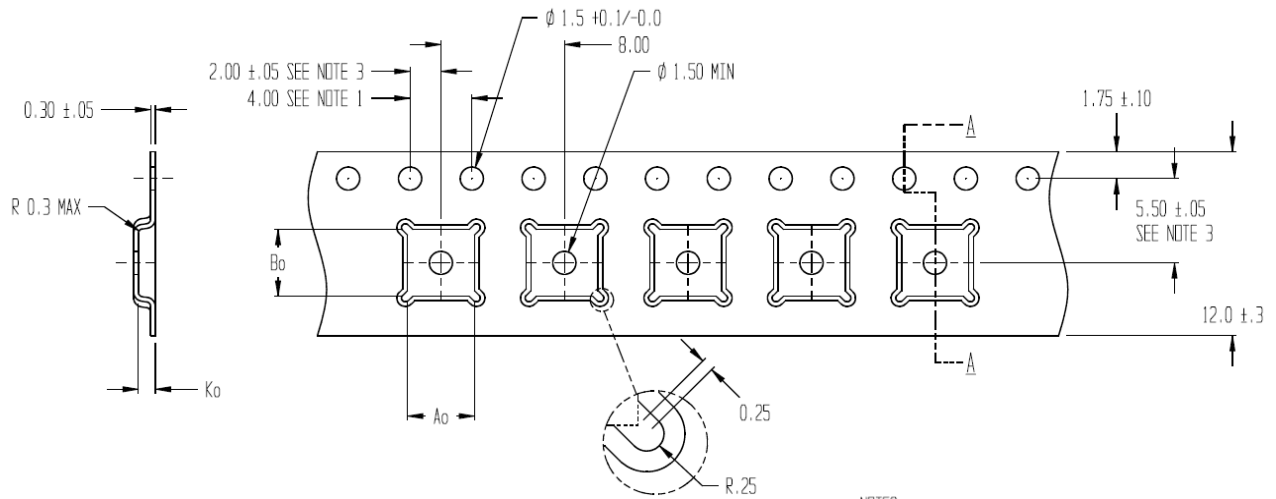
11.7 Tape & Reel Specification

SECTION A - A

 $A_o = 4.35$
 $B_o = 4.35$
 $K_o = 1.1$

TOLERANCES - UNLESS NOTED 1PL ±.2 2PL ±.10

ALL DIMENSIONS IN MILLIMETERS

Tape Dimensions

NOTES:

1. 10 SPROCKET HOLE PITCH CUMULATIVE TOLERANCE ±0.2
2. CAMBER IN COMPLIANCE WITH EIA 481
3. POCKET POSITION RELATIVE TO SPROCKET HOLE MEASURED AS TRUE POSITION OF POCKET, NOT POCKET HOLE

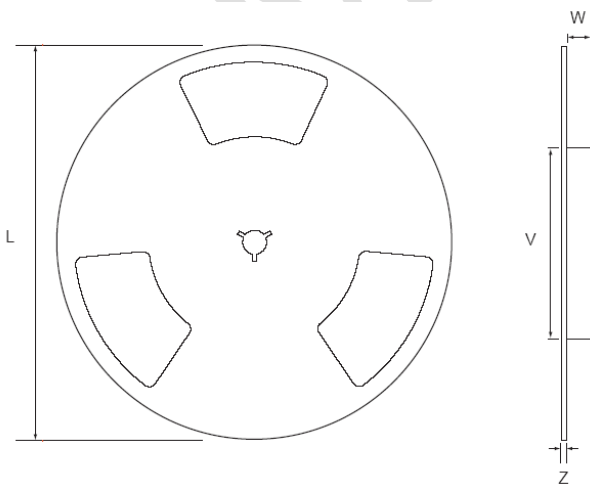
Reel Outline Drawing
Reel Dimensions and Package Size

| PACKAGE SIZE | REEL (mm) | | | |
|--------------|-----------|-----|------|-----|
| | L | V | W | Z |
| 4x4 | 330 | 100 | 13.2 | 2.2 |

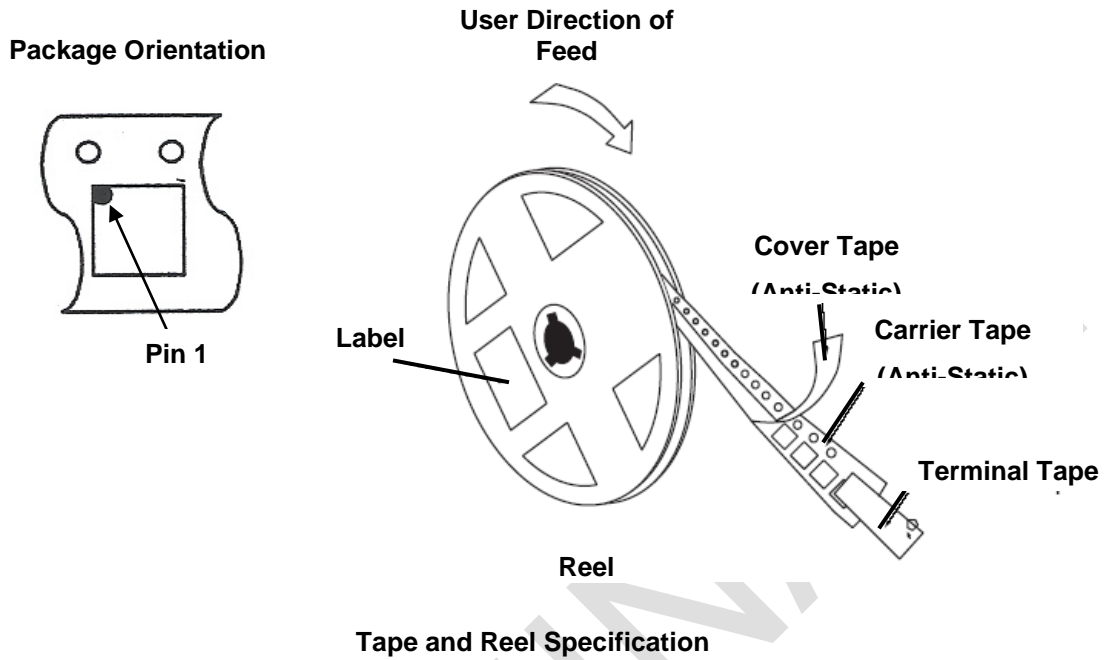

Tape and Reel Specification

Reel Specifications

| | |
|------------------------|--------|
| Quantity Per Reel | 5,000 |
| Reels per Box | 1 |
| Boxes Per Carton (max) | 3 |
| Pcs/Carton (max) | 15,000 |

11.8 Label

| | | |
|------------------------|----------------|---------------------|
| InvenSense | | |
| DEVICE (IP) : MPU-6000 | P.O: | REEL QTY (Q) : 5000 |
| | | |
| LOT 1 (IT) : 123456-A | D/C (D) : 1234 | QTY (Q) : 5000 |
| | | |
| LOT 2 (IT) : | D/C (D) : | QTY (Q) : |
| | | |
| Reel Date : 13/10/09 | | QC STAMP |



Location of Label

11.9 Packaging

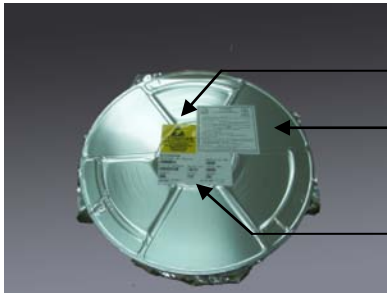

Moisture Barrier Bag
 With Labels

- ESD Anti-static Label
- Moisture-Sensitivity
- Caution Label
- Tape & Reel
- Barcode Label

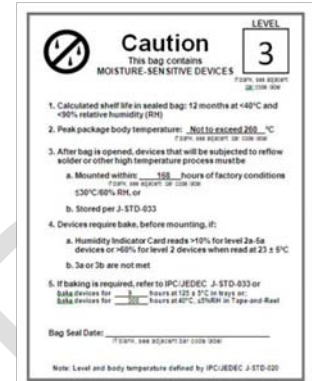

Moisture-Sensitive Caution Label



Reel in Box



Box with Tape & Reel Label

PRELIMINARY



12 Reliability

12.1 Qualification Test Policy

InvenSense's products complete a Qualification Test Plan before being released to production. The Qualification Test Plan for the MPU-60X0 followed the JEDEC 47G.01 Standard, "Stress-Test-Driven Qualification of Integrated Circuits," with the individual tests described below.

12.2 Qualification Test Plan

Accelerated Life Tests

| TEST | Method/Condition | Lot Quantity | Sample / Lot | Acc / Reject Criteria |
|--|--|--------------|--------------|-----------------------|
| High Temperature Operating Life (HTOL/LFR) | JEDEC JESD22-A108C, Dynamic, 3.63V biased, $T_j > 125^\circ\text{C}$ [read-points 168, 500, 1000 hours] | 3 | 77 | (0/1) |
| Highly Accelerated Stress Test ⁽¹⁾ (HAST) | JEDEC JESD22-A118 Condition A, 130°C , 85%RH, 33.3 psia., unbiased, [read-point 96 hours] | 3 | 77 | (0/1) |
| High Temperature Storage Life (HTS) | JEDEC JESD22-A103C, Cond. A, 125°C , Non-Biased Bake [read-points 168, 500, 1000 hours] | 3 | 77 | (0/1) |

Device Component Level Tests

| TEST | Method/Condition | Lot Quantity | Sample / Lot | Acc / Reject Criteria |
|---|--|--------------|--------------|-----------------------|
| ESD-HBM | JEDEC JESD22-A114F, (1.5KV) | 1 | 3 | (0/1) |
| ESD-MM | JEDEC JESD22-A115-A, (200V) | 1 | 3 | (0/1) |
| Latch Up | JEDEC JESD78B Class II (2), 125°C ; Level B $\pm 60\text{mA}$ | 1 | 6 | (0/1) |
| Mechanical Shock | JEDEC JESD22-B104C, Mil-Std-883H, method 2002.5, Cond. E, 10,000g's, 0.2ms, $\pm X, Y, Z$ – 6 directions, 5 times/direction | 3 | 5 | (0/1) |
| Vibration | JEDEC JESD22-B103B, Variable Frequency (random), Cond. B, 5-500Hz, X, Y, Z – 4 times/direction | 3 | 5 | (0/1) |
| Temperature Cycling (TC) ⁽¹⁾ | JEDEC JESD22-A104D Condition N, [-40°C to +85°C], Soak Mode 2 [5'], 100 cycles | 3 | 77 | (0/1) |

Board Level Tests

| TEST | Method/Condition | Lot Quantity | Sample / Lot | Acc / Reject Criteria |
|---|---|--------------|--------------|-----------------------|
| Board Mechanical Shock | JEDEC JESD22-B104C, Mil-Std-883H, method 2002.5, Cond. E, 10000g's, 0.2ms, $\pm X, Y, Z$ – 6 directions, 5 times/direction | 1 | 5 | (0/1) |
| Board Temperature Cycling (TC) ⁽¹⁾ | JEDEC JESD22-A104D Condition N, [-40°C to +85°C], Soak Mode 2 [5'], 100 cycles | 1 | 40 | (0/1) |

(1) Tests are preceded by MSL3 Preconditioning in accordance with JEDEC JESD22-A113F



13 Environmental Compliance

The MPU-60X0 is RoHS and Green compliant and is in full environmental compliance as evidenced in report HS-MPU-6000A, Materials Declaration Data Sheet.

Environmental Declaration Disclaimer:

InvenSense believes this environmental information to be correct but cannot guarantee accuracy or completeness. Conformity documents for the above component constitutes are on file. InvenSense subcontracts manufacturing and the information contained herein is based on data received from vendors and suppliers, which has not been validated by InvenSense.

PRELIMINARY



This information furnished by InvenSense is believed to be accurate and reliable. However, no responsibility is assumed by InvenSense for its use, or for any infringements of patents or other rights of third parties that may result from its use. Specifications are subject to change without notice. InvenSense reserves the right to make changes to this product, including its circuits and software, in order to improve its design and/or performance, without prior notice. InvenSense makes no warranties, neither expressed nor implied, regarding the information and specifications contained in this document. InvenSense assumes no responsibility for any claims or damages arising from information contained in this document, or from the use of products and services detailed therein. This includes, but is not limited to, claims or damages based on the infringement of patents, copyrights, mask work and/or other intellectual property rights.

Certain intellectual property owned by InvenSense and described in this document is patent protected. No license is granted by implication or otherwise under any patent or patent rights of InvenSense. This publication supersedes and replaces all information previously supplied. Trademarks that are registered trademarks are the property of their respective companies. InvenSense sensors should not be used or sold in the development, storage, production or utilization of any conventional or mass-destructive weapons or for any other weapons or life threatening applications, as well as in any other life critical applications such as medical equipment, transportation, aerospace and nuclear instruments, undersea equipment, power plant equipment, disaster prevention and crime prevention equipment.

InvenSense®, MotionCommand®, TouchAnywhere®, and AirSign® are registered trademarks of InvenSense, Inc. MPU™, MPU-6000™, MPU-6050™, MPU-60X0™, Motion Processing Unit™, MotionFusion™, MotionProcessing™, MotionApps™, Digital Motion Processor™, Digital Motion Processing™, DMP™, BlurFree™, and InstantGesture™ are trademarks of InvenSense, Inc.

©2011 InvenSense, Inc. All rights reserved.

